



Network Control

MOXA

Topics covered in this paper

- **What is QoS?**
- **What is IGMP Snooping?**
- **What is VLAN?**



QoS

What is QoS?

Quality of Service (QoS) provides Traffic Prioritization Capability to ensure that important data is delivered consistently and predictably.



When Do We Need QoS?

Aggregation

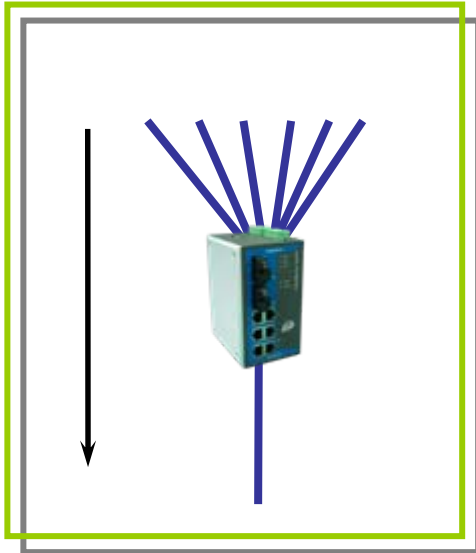

Speed Mismatch

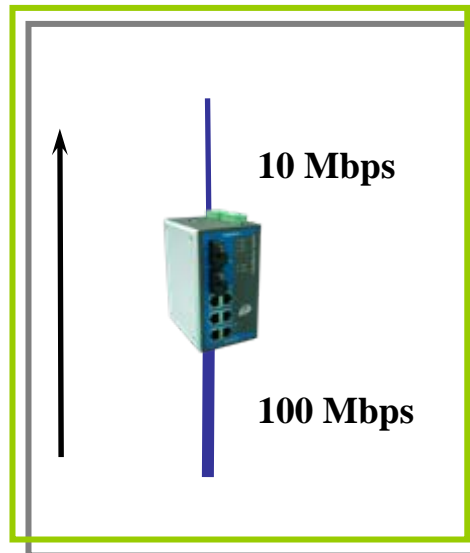

LAN to WAN

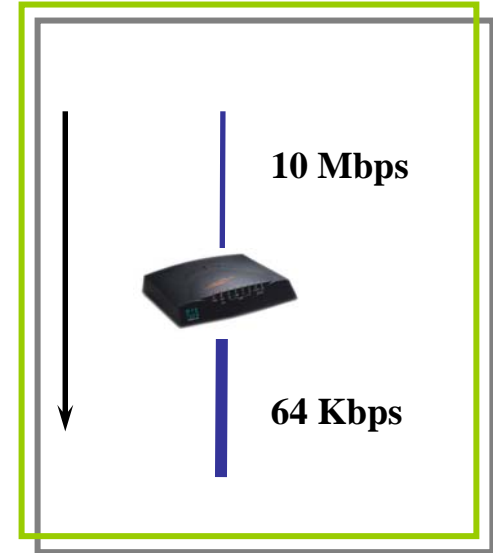

QoS to Increase Determinism

- Supports interoperable **IEEE Standard – 802.1p/1Q**, to maintain a consistent QoS policy across a switch
- Supports Layer 3 **TOS/DiffServ**



Layer 2: 802.1p/802.1Q CoS

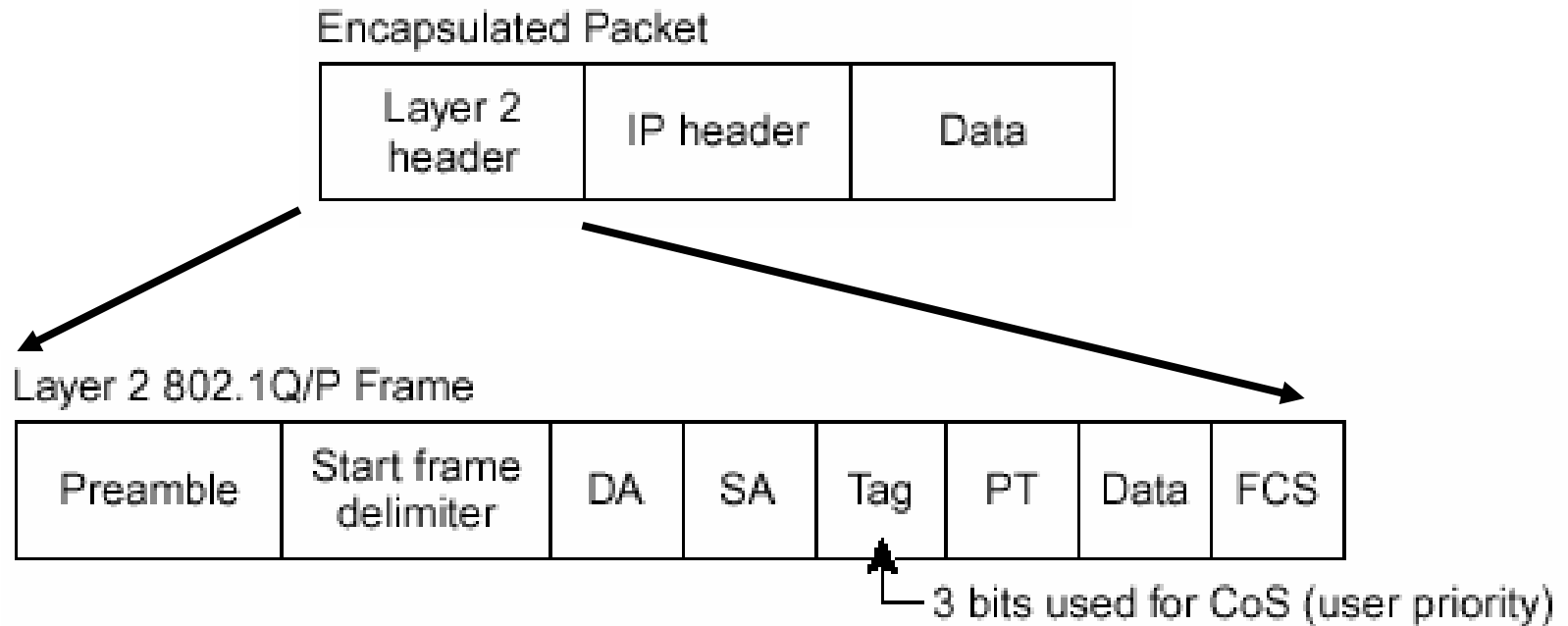

- Layer 2 of 802.1Q frame: Each packet uses 3 bits

Class-Of-Service (COS) carries classification information



Layer 3: DiffServ/ToS

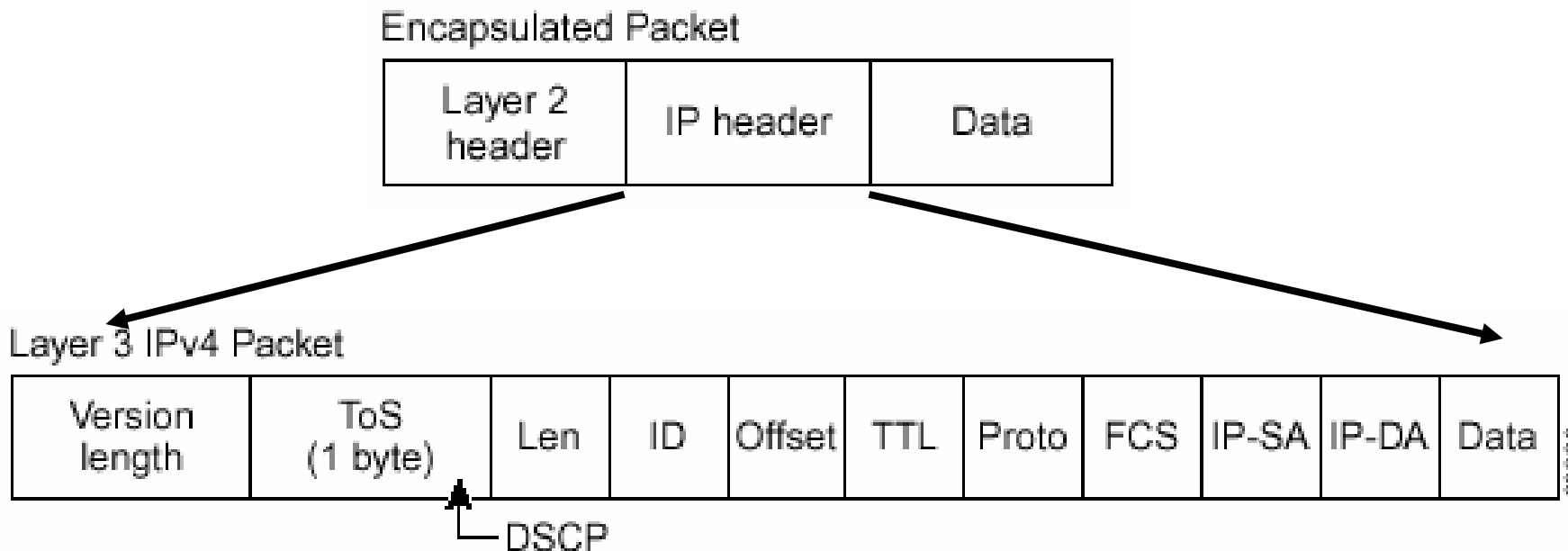

Layer 3 DiffServ Architecture: Each packet uses **Type-Of-Service (TOS)** field in IP header to carry classification information (Differentiated Services Code Point - DSCP)



QoS Classification Settings

QoS Classification

Queuing Mechanism

Weight Fair(8:4:2:1)

Strict or Weighted Fair

	Inspect ToS	Inspect CoS	Default Port Priority
Port 1	<input checked="" type="checkbox"/>	<input checked="" type="checkbox"/>	Normal
Port 2	<input checked="" type="checkbox"/>	<input checked="" type="checkbox"/>	Normal
Port 3	<input checked="" type="checkbox"/>	<input checked="" type="checkbox"/>	Normal
Port 4	<input checked="" type="checkbox"/>	<input checked="" type="checkbox"/>	Normal
Port 5	<input checked="" type="checkbox"/>	<input checked="" type="checkbox"/>	Normal
Port 6	<input checked="" type="checkbox"/>	<input checked="" type="checkbox"/>	Normal
Port 7	<input checked="" type="checkbox"/>	<input checked="" type="checkbox"/>	Normal
Port 8	<input checked="" type="checkbox"/>	<input checked="" type="checkbox"/>	Normal

Low/Normal/
Medium/High



CoS Mapping

Mapping Table of CoS Value and Priority Queues

CoS	Priority Queue
0	Low
1	Low
2	Normal
3	Normal
4	Medium
5	Medium
6	High
7	High

Activate



TOS Mapping

Mapping Table of ToS (DSCP) Value and Priority Queues

ToS	Level	ToS	Level	ToS	Level	ToS	Level
0x00(1)	Low	0x04(2)	Low	0x08(3)	Low	0x0C(4)	Low
0x10(5)	Low	0x14(6)	Low	0x18(7)	Low	0x1C(8)	Low
0x20(9)	Low	0x24(10)	Low	0x28(11)	Low	0x2C(12)	Low
0x30(13)	Low	0x34(14)	Low	0x38(15)	Low	0x3C(16)	Low
0x40(17)	Normal	0x44(18)	Normal	0x48(19)	Normal	0x4C(20)	Normal
0x50(21)	Normal	0x54(22)	Normal	0x58(23)	Normal	0x5C(24)	Normal
0x60(25)	Normal	0x64(26)	Normal	0x68(27)	Normal	0x6C(28)	Normal
0x70(29)	Normal	0x74(30)	Normal	0x78(31)	Normal	0x7C(32)	Normal
0x80(33)	Medium	0x84(34)	Medium	0x88(35)	Medium	0x8C(36)	Medium
0x90(37)	Medium	0x94(38)	Medium	0x98(39)	Medium	0x9C(40)	Medium
0xA0(41)	Medium	0xA4(42)	Medium	0xA8(43)	Medium	0xAC(44)	Medium
0xB0(45)	Medium	0xB4(46)	Medium	0xB8(47)	Medium	0xBC(48)	Medium
0xC0(49)	High	0xC4(50)	High	0xC8(51)	High	0xCC(52)	High

Activate



QoS Summary

QoS maximizes your current network bandwidth.



IGMP Snooping

Why IGMP Snooping?

Multicast Service

⇒ Good for one-to-many traffic

IGMP

⇒ The most widely used IP multicast protocol in WAN

IGMP Snooping

⇒ Makes LAN environment multicast aware



Unicast vs. Multicast

Unicast Application:

Repeatedly sends the same unicast packets to multiple hosts

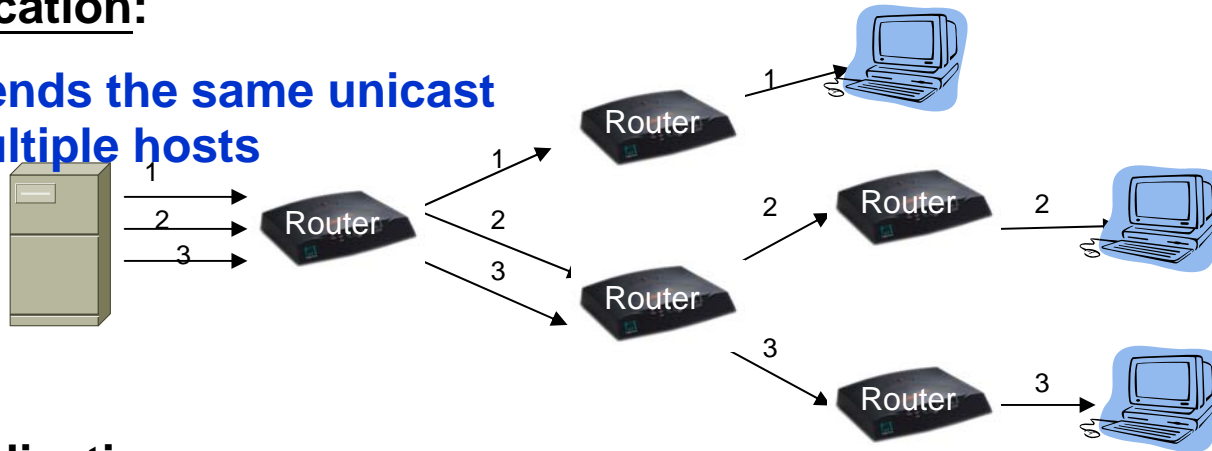

Multicast Application:

Sends one multicast packet to multiple hosts

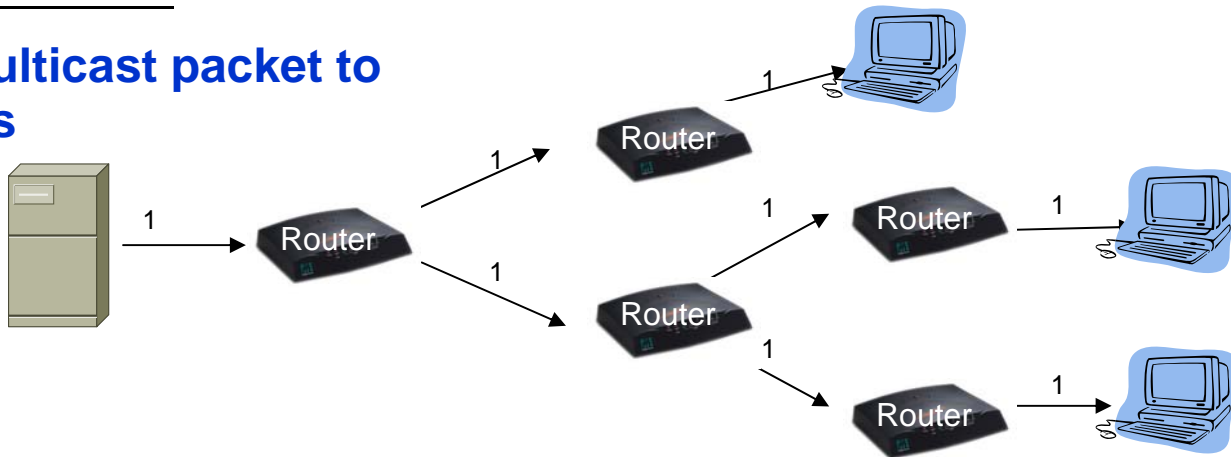

Why IGMP Snooping?

Multicast Service

⇒ Good for one-to-many traffic

IGMP

⇒ The most widely used IP multicast protocol in WAN

IGMP Snooping

⇒ Makes LAN environment multicast aware



What is IGMP?

- Internet Group Management Protocol (IGMP)
- How hosts tell routers about group membership
- Routers query group membership from host on the connected LAN
- RFC 1112: IGMP V1
- RFC 2236: IGMP V2 (Current version)
- IGMP v3 is prepared
- Supported on UNIX, PC, MACs.



Example:

IGMPv1 – Joining a Group

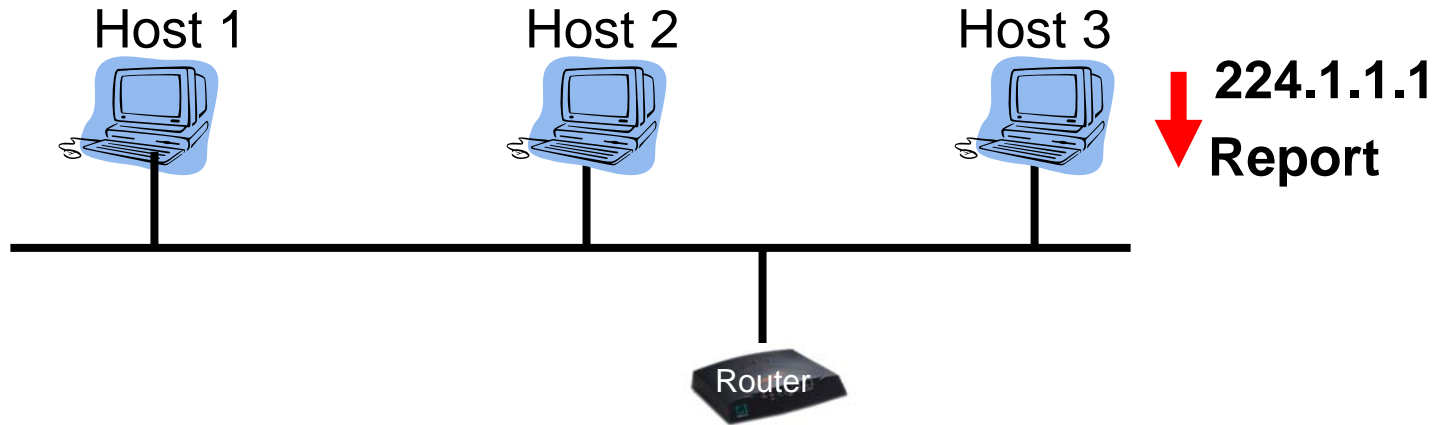

- Joining member sends report to 224.1.1.1 immediately upon joining
- IP Multicast address – 224.0.0.0 ~ 239.255.255.255 (Class D address)
- 224.0.0.1 – The multicast address for all hosts on subnet
- 224.0.0.2 – The multicast address for all routers on subnet



Example: IGMPv1 – General Queries

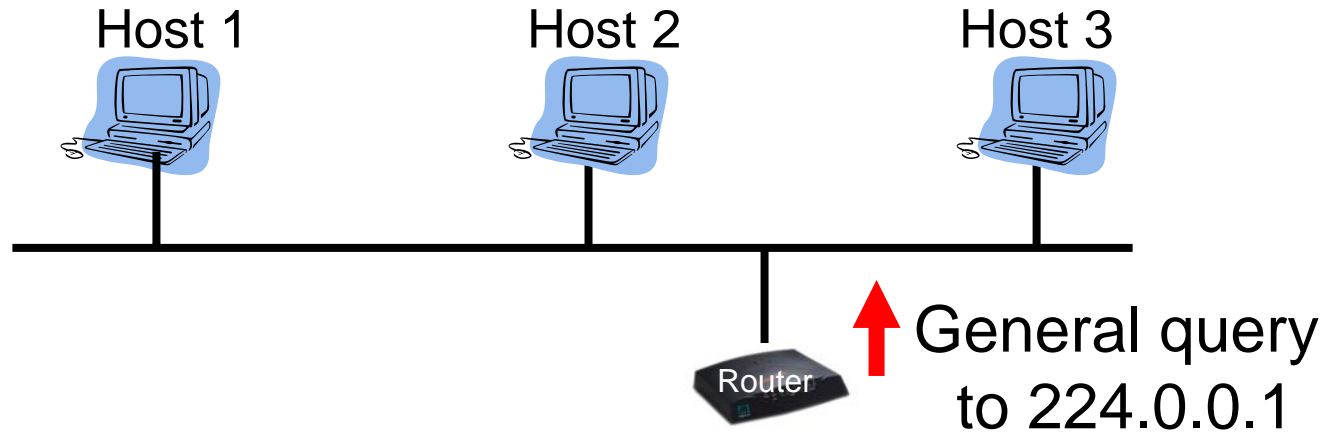

- Periodically sends general queries to 224.0.0.1 to determine membership

- IP Multicast address – 224.0.0.0 ~ 239.255.255.255 (Class D address)
- 224.0.0.1 – The multicast address for all hosts on subnet
- 224.0.0.2 – The multicast address for all routers on subnet



Why IGMP Snooping?

Multicast Service

⇒ Good for one-to-many traffic

IGMP

⇒ The most widely used IP multicast protocol in WAN

IGMP Snooping

⇒ **Makes LAN environment multicast aware**



IGMP Snooping Helps Save Bandwidth

All end stations need to handle the traffic whether they need it or not.

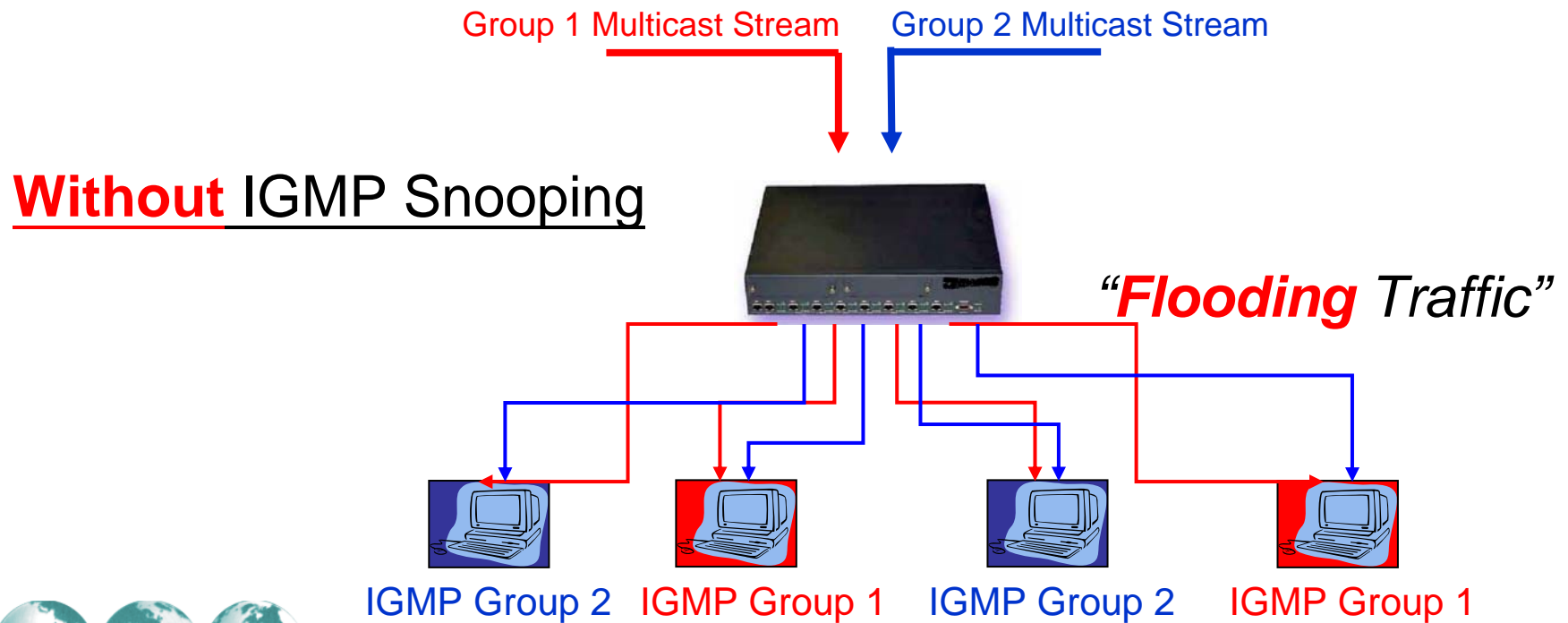

IGMP Snooping helps Save Bandwidth

End stations only receive dedicated traffic belonging to the same group.

With IGMP Snooping

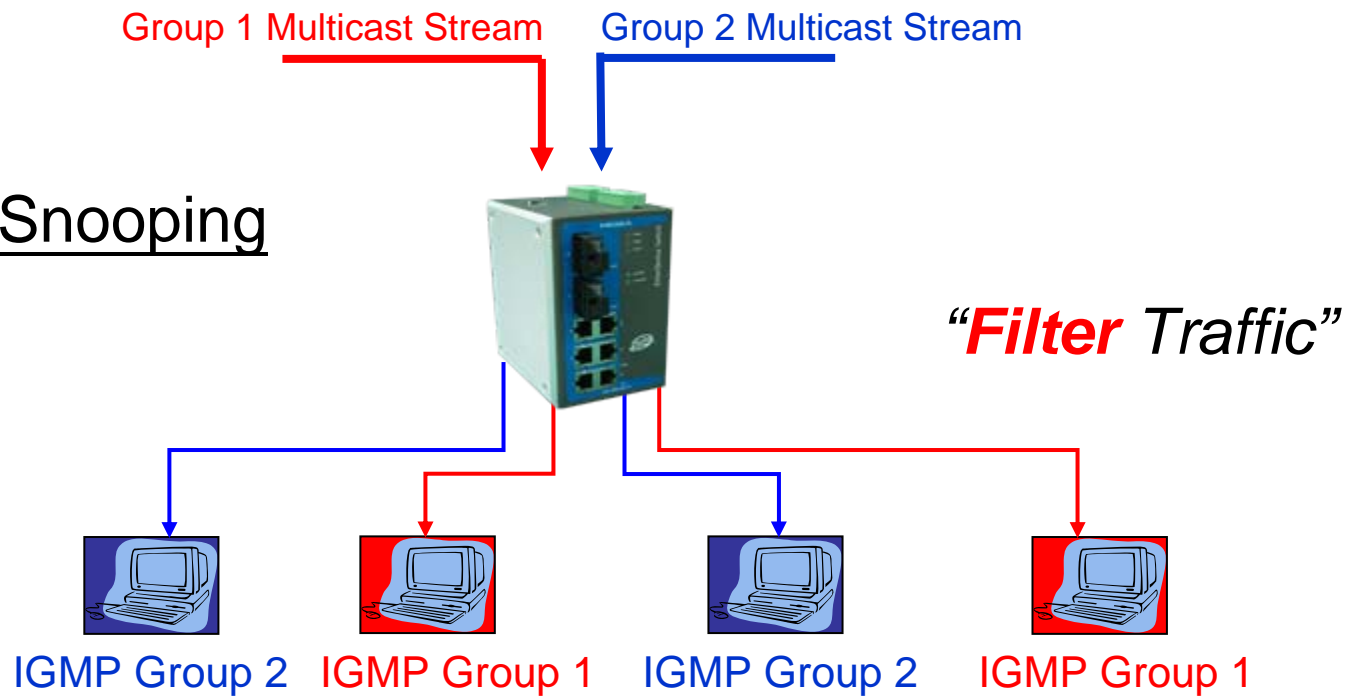

IGMP Snooping Settings

IGMP Snooping Setting

Querier Interval (s)

Set the query interval of Querier function globally.

Current VLAN List

IGMP Snooping Enable

Enable the IGMP Snooping function globally.

Index	VID	IGMP Snooping	Static Multicast Router Port								Querier
1	1	<input checked="" type="checkbox"/> Enable	<input type="checkbox"/> Port1	<input type="checkbox"/> Port2	<input type="checkbox"/> Port3	<input type="checkbox"/> Port4	<input type="checkbox"/> Port5	<input type="checkbox"/> Port6	<input type="checkbox"/> Port7	<input type="checkbox"/> Port8	<input checked="" type="checkbox"/> Enable
2	2	<input checked="" type="checkbox"/> Enable	<input type="checkbox"/> Port1	<input type="checkbox"/> Port2	<input type="checkbox"/> Port3	<input type="checkbox"/> Port4	<input type="checkbox"/> Port5	<input type="checkbox"/> Port6	<input checked="" type="checkbox"/> Port7	<input type="checkbox"/> Port8	<input type="checkbox"/> Disable
3	4094	<input checked="" type="checkbox"/> Enable	<input type="checkbox"/> Port1	<input type="checkbox"/> Port2	<input type="checkbox"/> Port3	<input type="checkbox"/> Port4	<input type="checkbox"/> Port5	<input type="checkbox"/> Port6	<input type="checkbox"/> Port7	<input type="checkbox"/> Port8	<input checked="" type="checkbox"/> Enable

Enable the IGMP Snooping function per VLAN.

Select which ports are connecting to the multicast routers.

Enable the querier function of EDS-508.

Activate

Add entry



IGMP Table

Current VLAN List

IGMP Snooping Enable

Index	VID	IGMP Snooping	Static Multicast Router Port				Querier
1	1	<input checked="" type="checkbox"/> Enable	<input type="checkbox"/> Port1	<input type="checkbox"/> Port2	<input type="checkbox"/> Port3	<input type="checkbox"/> Port4	<input checked="" type="checkbox"/> Enable
			<input type="checkbox"/> Port5	<input type="checkbox"/> Port6	<input checked="" type="checkbox"/> Port7	<input type="checkbox"/> Port8	

Current Active IGMP Groups

VID	Auto Learned Multicast Router Port	Static Multicast Router Port	Act as Querier	Active IGMP Groups		
				IP	MAC	Members Port
1	8	7	Yes	239.238.238.224	01-00-5E-6E-EE-E0	3



Add Static Multicast MAC

Add Static Multicast MAC Address

Current Static Multicast MAC Address List

<input type="checkbox"/> Select All	Index	MAC	Join Port
<input type="checkbox"/>	1	01-00-5e-00-11-12	5
<input type="checkbox"/>	2	01-00-5e-12-00-11	7

Select the join ports of this multicast group

Remove Select

Add New Static Multicast MAC Address to the List

MAC Address

 - - -

Join Port

 Port 1 Port 2 Port 3 Port 4 Port 5 Port 6 Port 7 Port 8

Add to List

Input the desired multicast MAC address.

01:00:5E:00:00:00 -
01:00:5E:FF:FF:FF



IGMP Snooping Summary

IGMP Snooping makes switch IGMP aware to establish the best path for multicast service, to save LAN bandwidth.



VLAN

What is VLAN?

- A Virtual LAN (VLAN) is a group of devices that can be located anywhere on a network, but which communicate as if they are on the same physical segment.
- With VLANs, you can easily segment your network logically without being restricted by physical connections

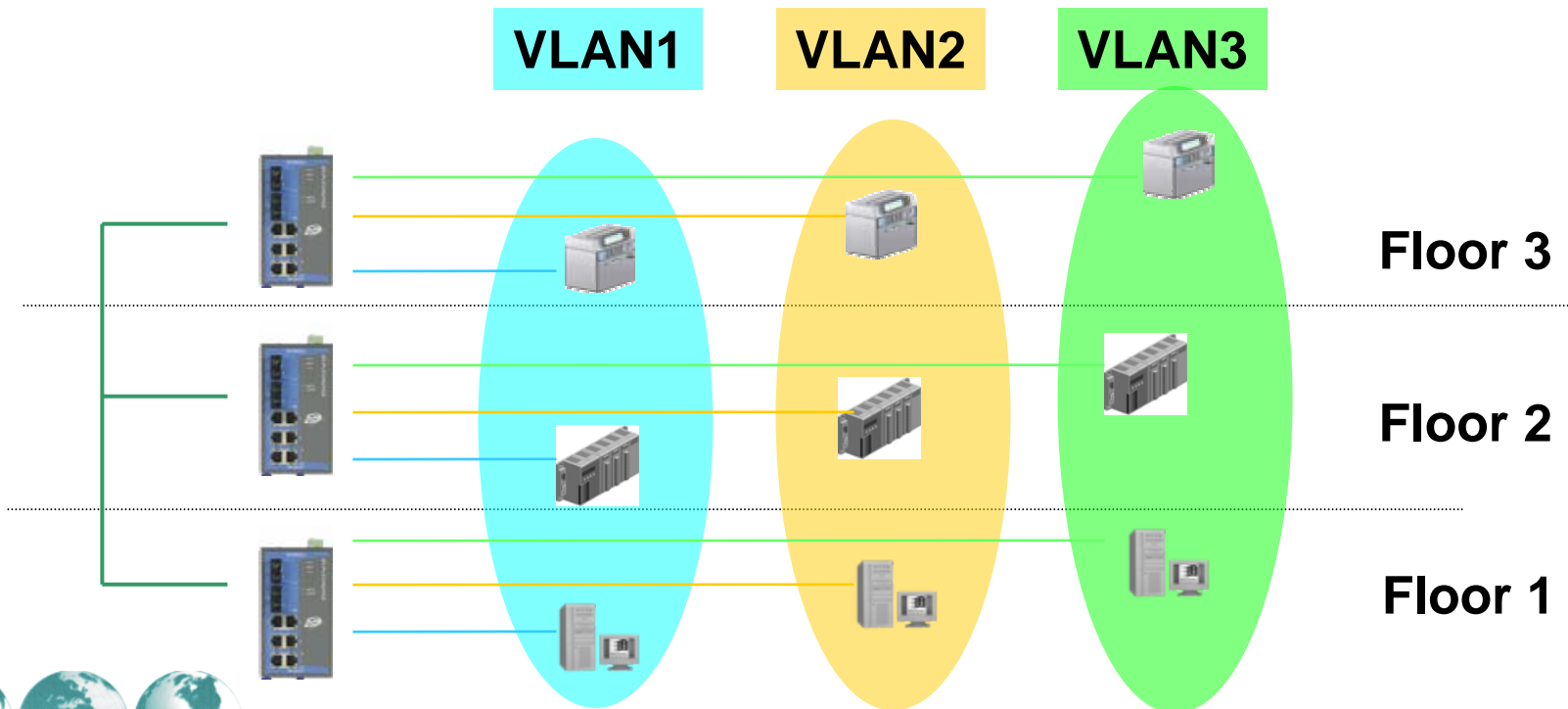

Benefits of a VLAN

- **VLANs ease network changes**
- **VLANs enhance network security**
- **VLANs help control traffic**



VLANs ease network changes

- VLANs allow you to group devices as if they are connected by physical connections. **You do not need to do any re-cabling.**

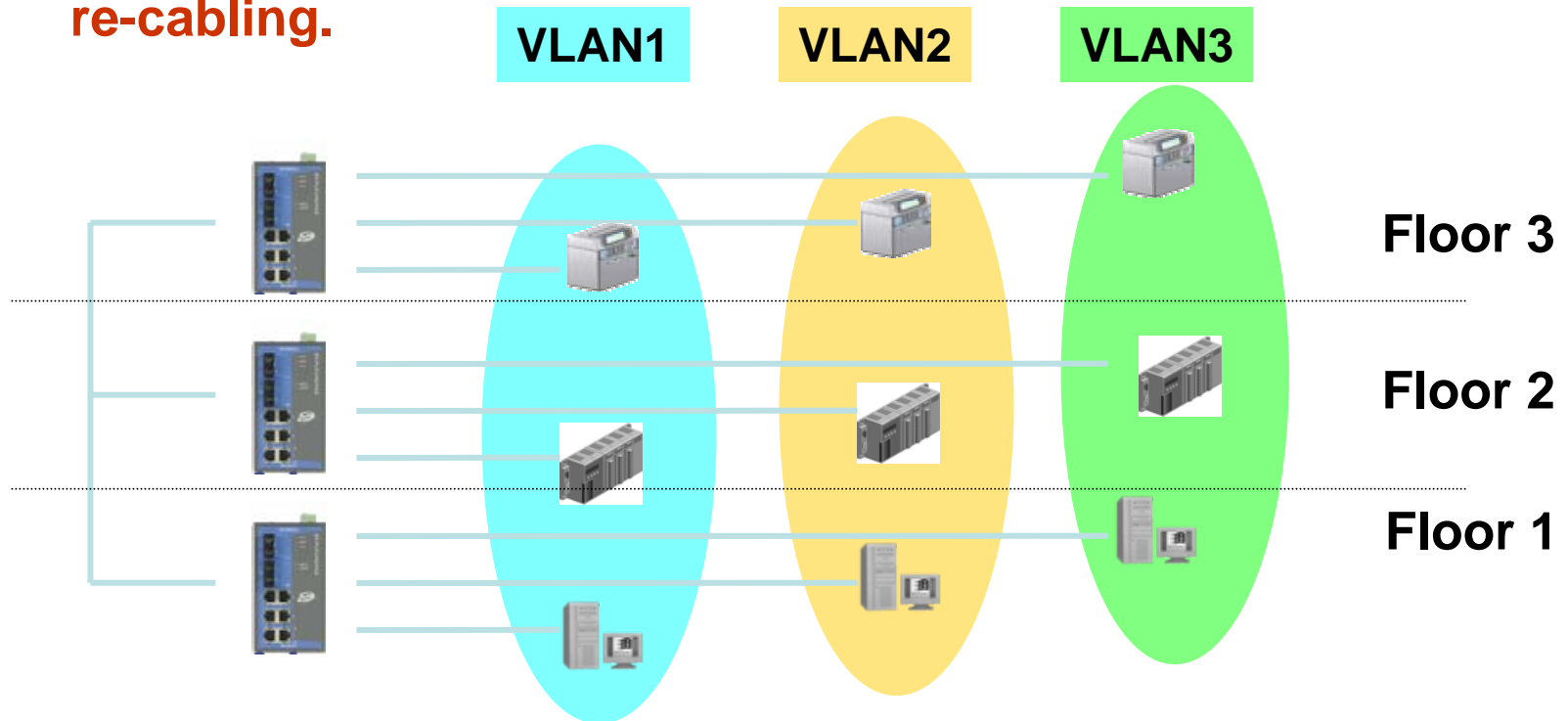

VLANs enhance network security

- Devices within each VLAN can only communicate with other devices on the same VLAN.

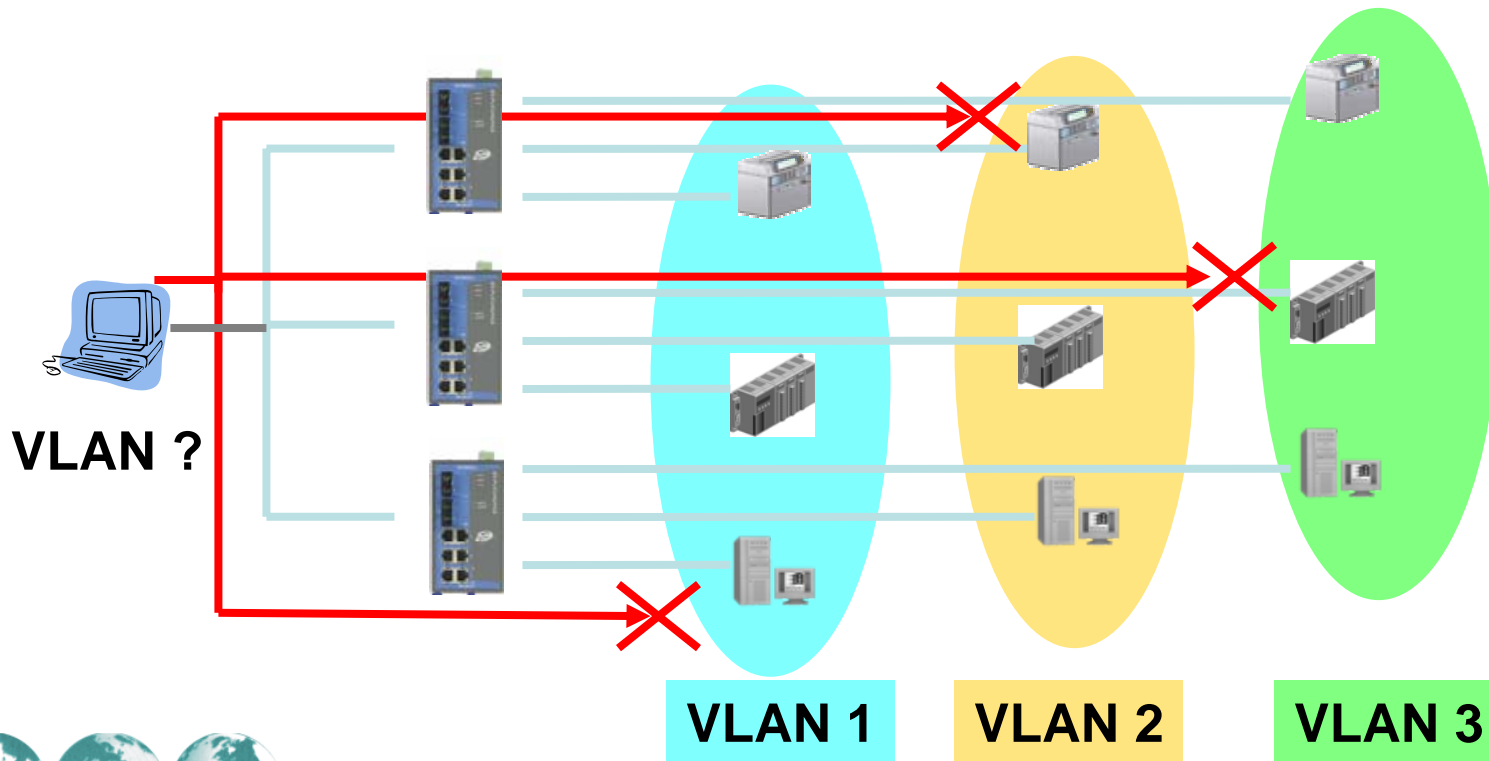

VLANs help control traffic

- Increases efficiency by separating traffic from different groups to prevent wasting unwanted broadcast/multicast packets.

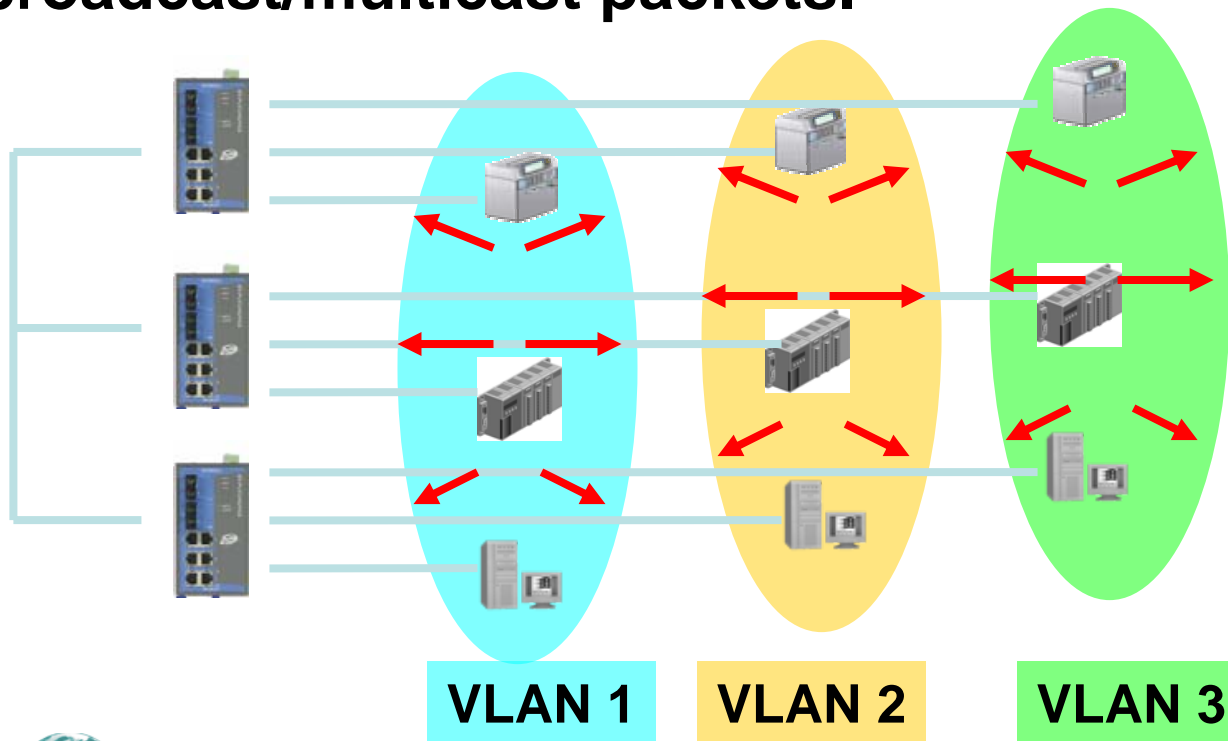

802.1Q Tag Frame

- Uses an extra tag in the MAC header to identify the VLAN membership of a frame across switch/bridges. This tag is used for VLAN and QoS priority identification.

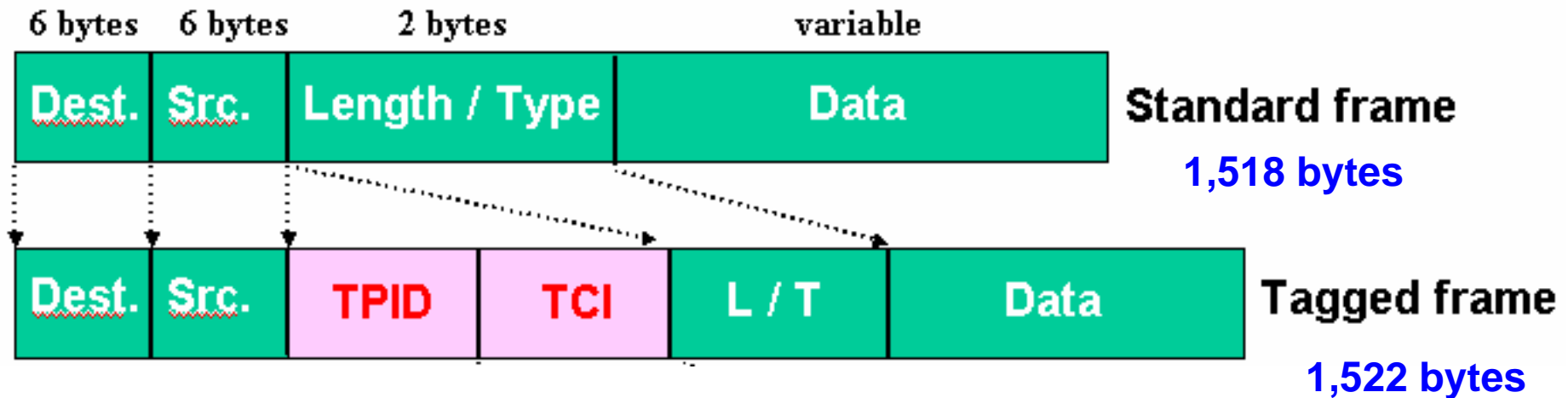

802.1Q Tag Frame

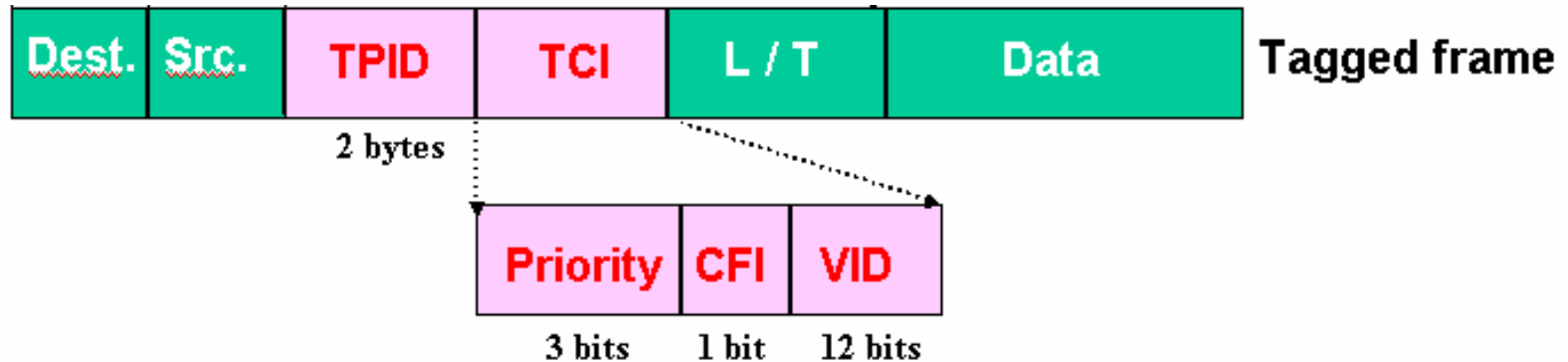

- **Priority:** The first three bits of the TCI define user priority, giving eight (2^3) priority levels.
- **VID:** VLAN ID identifies the VLAN, which is basically used by the standard 802.1Q. The ID has 12 bits, allowing the identification of 4096 (2^{12}) VLANs. Of the 4096 possible VIDs, a VID of 0 is used to identify priority frames and value 4095 (FFF) is reserved, so the maximum possible VLAN configurations are 4,094.



Configuration of a VLAN

- **Access Port** is used to connect single devices without tag.
- **Trunk Port** connects another 802.1Q VLAN aware switch /hubs.
- **Hybrid Port** connects LAN that combines tagged and/or untagged devices and/or other switches

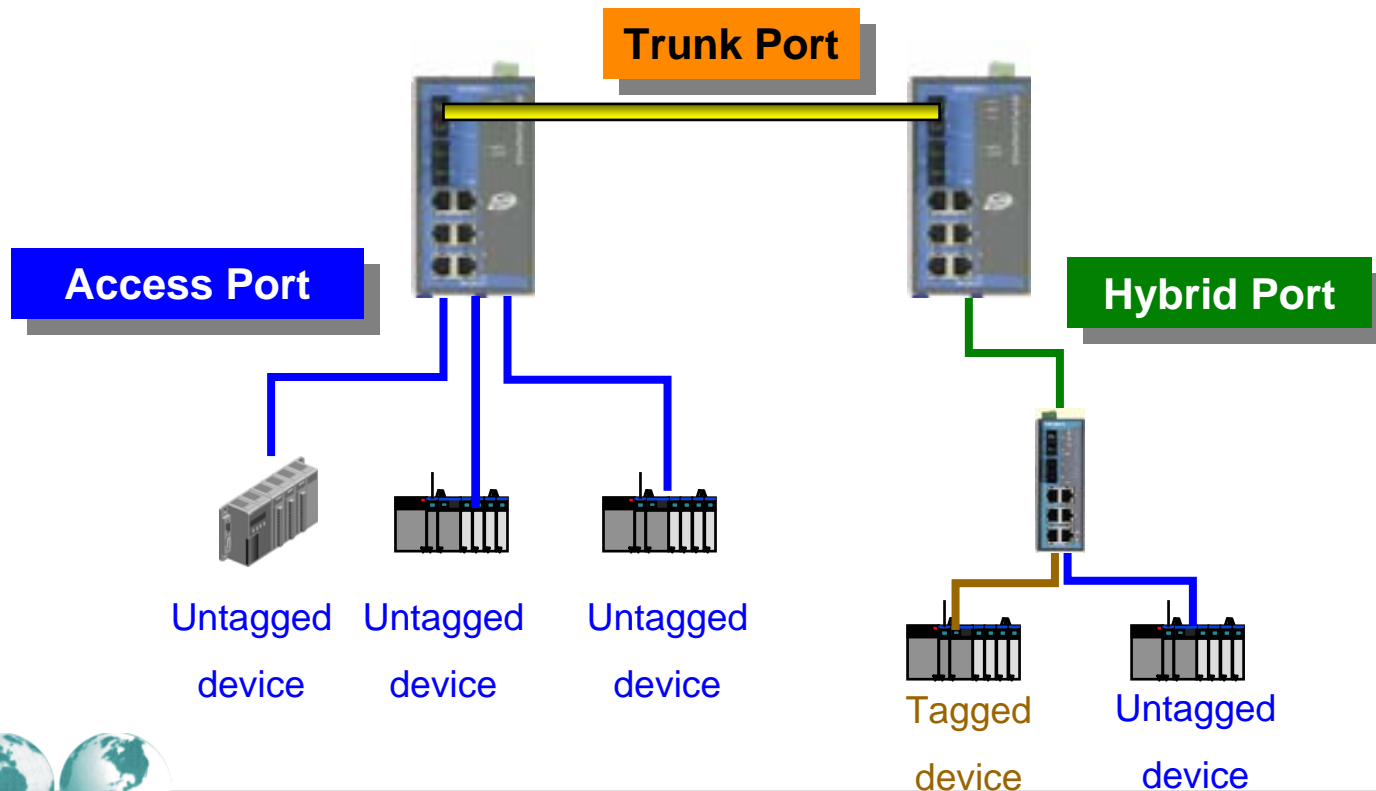

Access Port

- **Access Port** is used to connect single devices without tag.
- The VLAN Switch adds a tag (PVID) to received packets, and removes tag when transmitting packets
- Only one specific PVID for each port
- Over 90% of devices are untagged

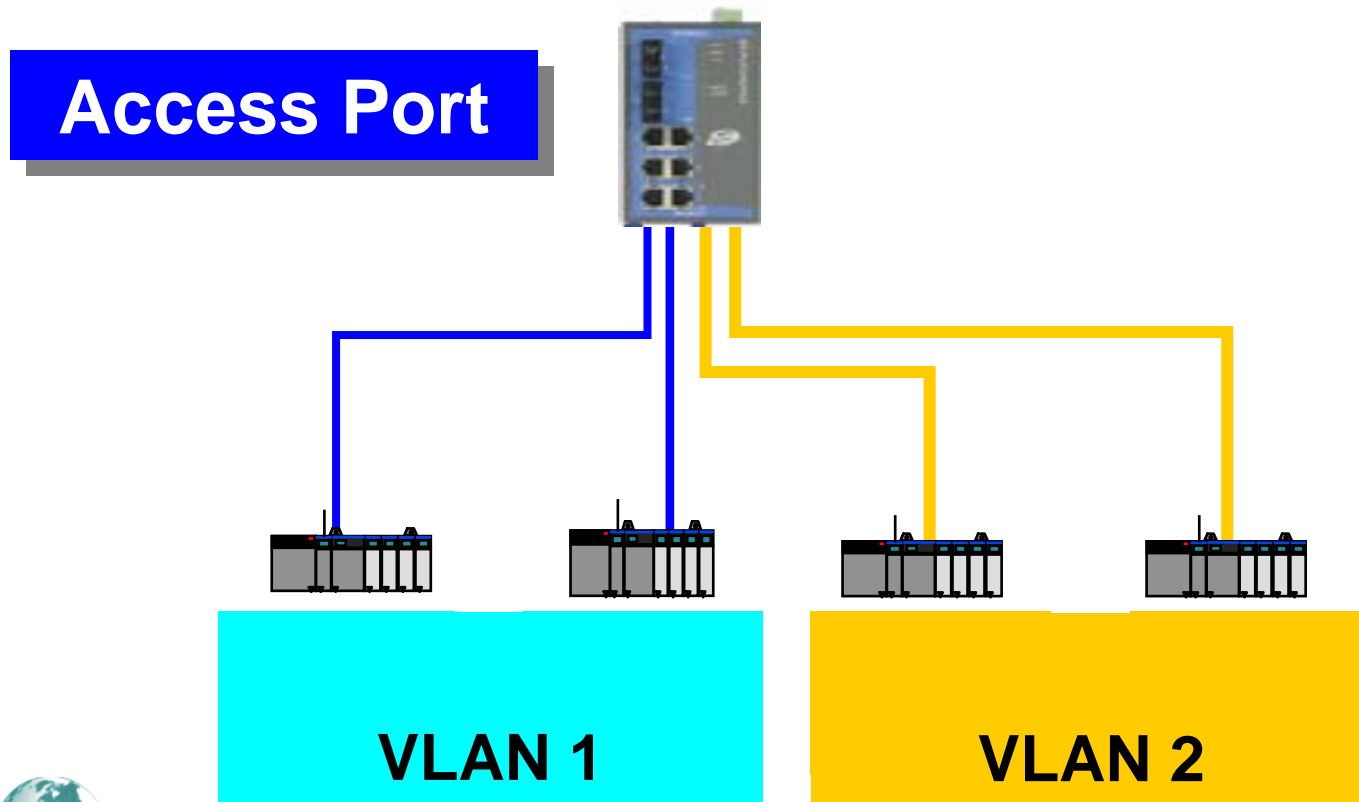

Access Port Settings

VLAN Port Setting

Management VLAN ID

	Type	PVID	Fixed VLAN (Tagged)	Forbidden VLAN
Port 1	<input type="text" value="Access"/>	<input type="text" value="1"/>	<input type="text"/>	<input type="text"/>
Port 2	<input type="text" value="Access"/>	<input type="text" value="1"/>	<input type="text"/>	<input type="text"/>
Port 3	<input type="text" value="Access"/>	<input type="text" value="1"/>	<input type="text"/>	<input type="text"/>
Port 4	<input type="text" value="Access"/>	<input type="text" value="1"/>	<input type="text"/>	<input type="text"/>
Port 5	<input type="text" value="Acc"/>	<input type="text"/>	<input type="text"/>	<input type="text"/>
Port 6	<input type="text" value="Acc"/>	<input type="text"/>	<input type="text"/>	<input type="text"/>
Port 7	<input type="text" value="Trun"/>	<input type="text"/>	<input type="text"/>	<input type="text"/>
Port 8	<input type="text" value="Trunk"/>	<input type="text" value="1"/>	<input type="text"/>	<input type="text"/>

Set the port default VLAN ID for untagged devices that connect to the port

Designate this port as Access Port



Management VLAN

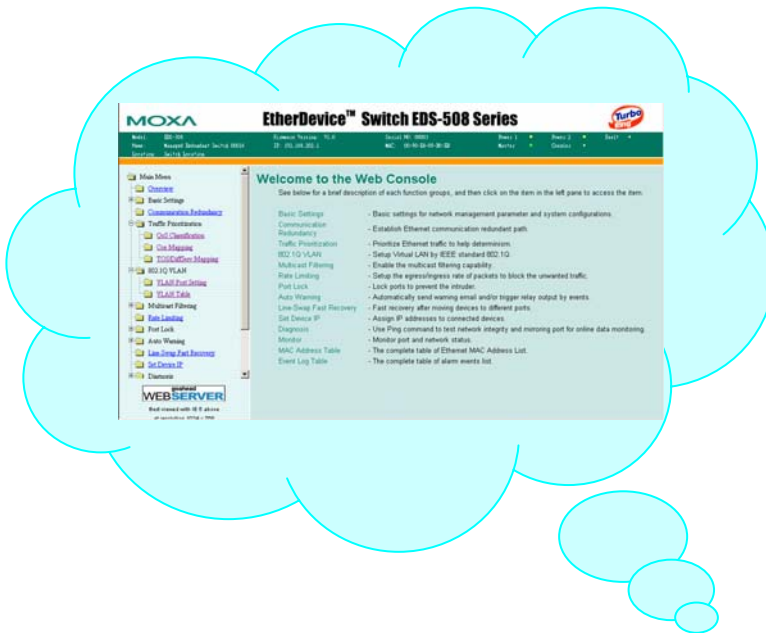

- Management VLAN ID should be set exactly as the port's VPID connected to your PC.
- All EDS-508s connected to the LAN recommended to set the same management VLAN ID



Management VLAN ID Settings

VLAN Port Setting

Set the management VLAN of this EDS-508.

Management VLAN ID

	Type	PVID	Fixed VLAN (Tagged)	Forbidden VLAN
Port 1	Access	1		
Port 2	Access	1		
Port 3	Access	1		
Port 4	Access	1		
Port 5	Access	1		
Port 6	Access	1		
Port 7	Trunk	1		
Port 8	Trunk	1		

Activate



Trunk Port

- Attach two VLAN Switches - carry Tag frames only
- **Trunk Port** connects another 802.1Q VLAN aware switch/hub
- Exchange GVRP messages between switches

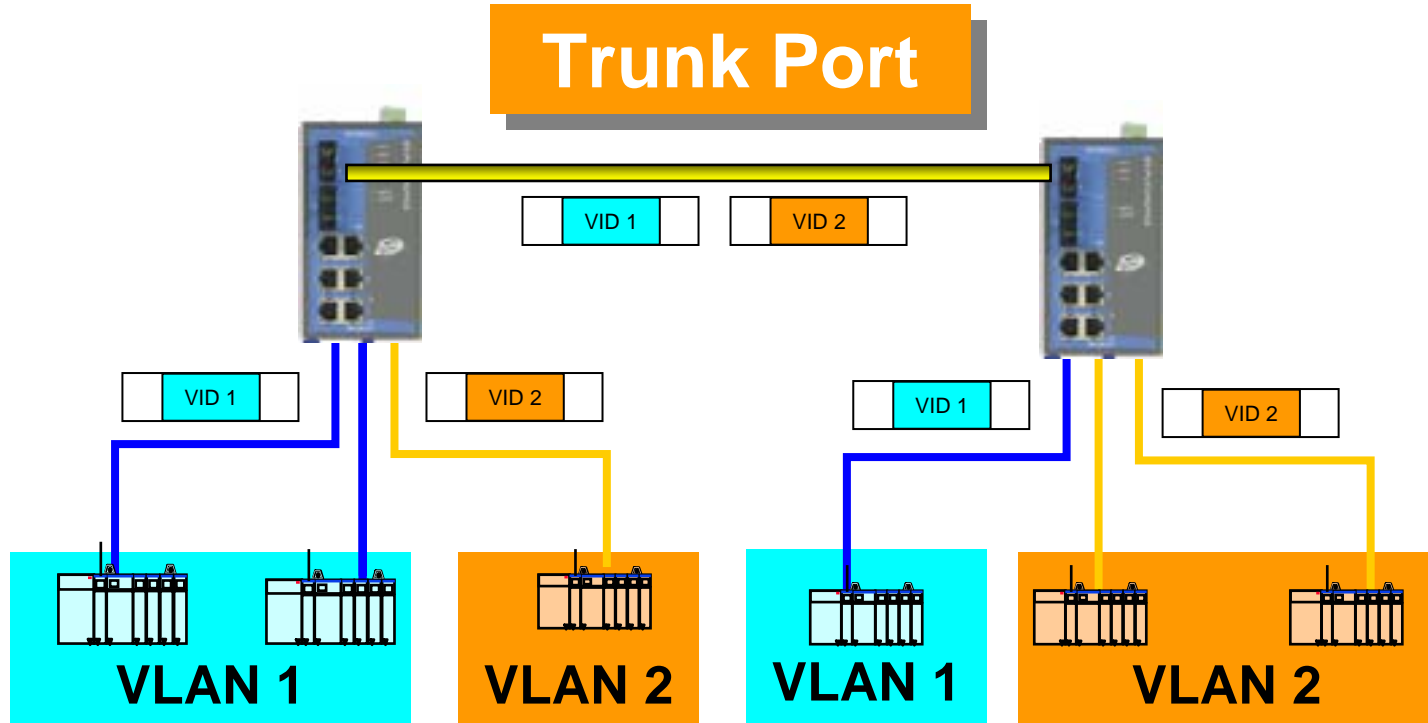

Trunk Port Settings

VLAN Port Setting

Management VLAN ID

	Type	PVID	Fixed VLAN (Tagged)	Forbidden VLAN
Port 1	Access	1		
Port 2	Access	1		
Port 3	Access	1		
Port 4	Access	1		
Port 5	Access			
Port 6	Access			
Port 7	Trunk			
Port 8	Trunk	1		

Designate this port as Trunk port

Set the VLAN IDs that will not be supported by this trunk port. Will be only valid for Trunk port

Activate



Hybrid Port

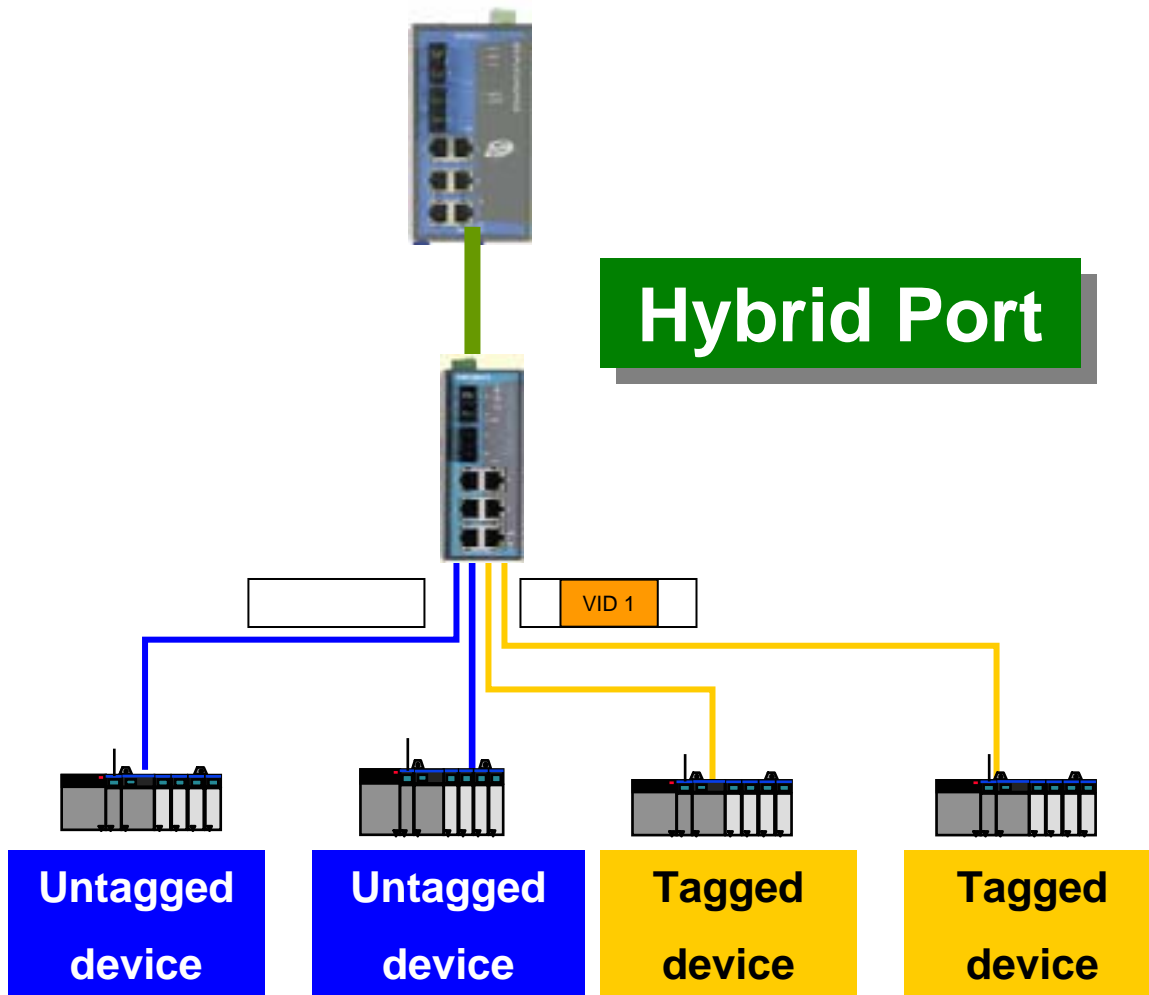

- **Hybrid Port** connects LAN that combines tagged and/or untagged devices and/or other switches
- All untagged devices are with the same PVID
- Keep the original VID of tagged device



Hybrid port Settings

VLAN Port Setting

Management VLAN ID

	Type	PVID	Fixed VLAN (Tagged)	Forbidden VLAN
Port 1	Access	1		
Port 2	Access	1		
Port 3	Access	1		
Port 4	Access	1		
Port 5	Acc			
Port 6	Acc			
Port 7	Trun			
Port 8	Trunk	1		

Designate this port as Trunk port

Set the other VLAN ID for tagged devices that connect to the "Trunk" port. Will be only valid for Trunk port

Activate



Which ports should be set as Trunk Port

- Connect to another 802.1Q VLAN aware switch
- Connect to tagged devices and designate a Fixed VLAN (Tagged) for it.
- Redundant Port, Coupling Port, and Coupling Control Port.

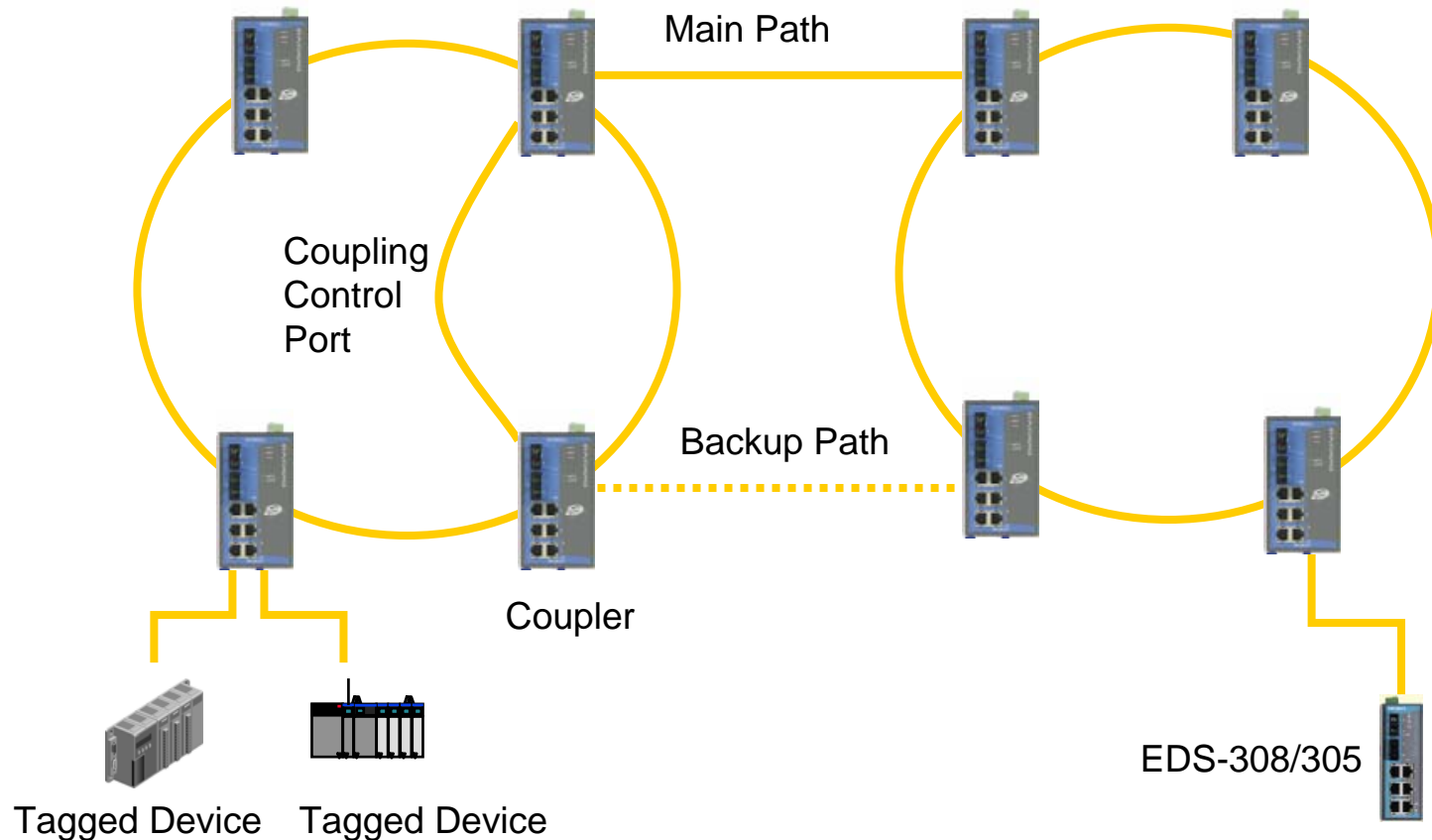

VLAN Table

- You can review the created VLAN groups, Joined Access Ports, and Trunk Ports

Management VLAN

Management VLAN 1

Current VLAN List

Index	VID	Joined Access Port	Joined Trunk Port
1	1	1,	3,7,8,
2	33	5,6,	2,
3	4094	4,	



VLAN Summary

VLANs provide flexible network planning to make it easier to manage networks without physically changing cables or rearranging hardware.

