



NPort 6110 Quick Installation Guide

Second Edition, September 2004

1. Overview

Welcome to Moxa NPort 6110 Modbus/TCP to Serial Communication Gateway, an easy to use RS-232/422/485 Modbus Comm. Gateway.

2. Package Checklist

Before installing NPort 6110, verify that the package contains the following items:

- 1 NPort 6110 Modbus/TCP to Serial Communication Gateway
- NPort 6110 Quick Installation Guide
- 100-240 VAC Universal Power Adaptor
- Product Warranty

Optional Accessories

DK-35A For 35 mm DIN-Rail; includes 4 screws

Notify your sales representative if any of the above items is missing or damaged.

3. Hardware Introduction

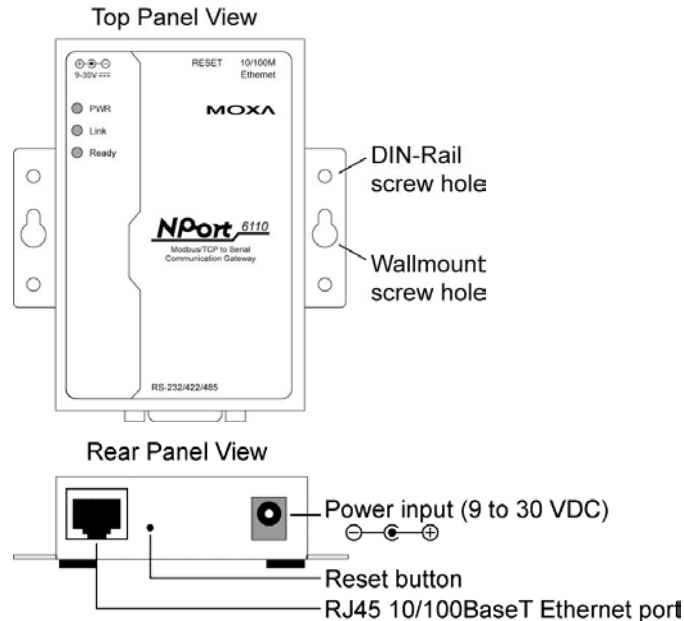
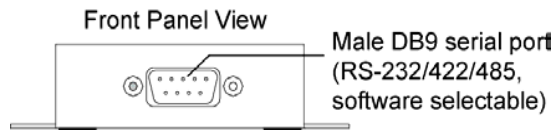

Reset Button—Press the *Reset button* continuously for

- 3 sec to erase the password
After 3 sec, the Ready LED will flash on/off every half second. Release the reset button at this time to erase the password.
- 10 sec to load factory defaults
After 10 sec, the Ready LED will flash on/off every fifth of a second. Release the reset button at this time to load factory defaults (IP=192.168.127.254; Netmask=255.255.255.0).

LED Indicators—NPort 6110's top panel contains three LED indicators, as described in the following table.

LED Name	LED Color	LED Function
PWR	red	Power is on.
	Off	Power is off, or power error condition exists.
Link	Orange	10 Mbps Ethernet connection.
	Green	100 Mbps Ethernet connection.
	Off	Ethernet cable is disconnected, or has a short.
Ready	green	System is ready.
	Off	System error.

4. Hardware Installation Procedure

STEP 1: After removing NPort 6110 from the box, the first thing you should do is attach the power adaptor.

STEP 2: Connect NPort 6110 to a network. Use a standard straight-through Ethernet cable to connect to a Hub or Switch. When setting up or testing NPort 6110, you might find it convenient to connect directly to your computer's Ethernet port. In this case, use a cross-over Ethernet cable.

STEP 3: Connect NPort 6110's serial port to an RS-232, RS-422, or RS-485 serial device.

STEP 4: Placement Options

In addition to placing NPort 6110 on a desktop or other horizontal surface, you may also make use of the DIN-Rail or Wall Mount options, as illustrated here.

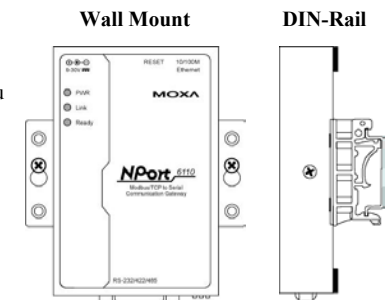

5. Software Installation Information

To install **NPort Modbus Configuration Gateway**, insert the NPort 6110 Document & Software CD into your computer's CD-ROM drive. Once the **NPort Installation CD** window opens, click on the **Install Utility** button, and then follow the instructions on the screen.

To view detailed information about NPort Modbus Configuration Gateway, click on the **Documents** button, and then click on the **English** button to open the pdf version of the NPort 6110 User's Manual.

P/N: 18020611001

6. Pin Assignments and Cable Wiring

DB9 Male Connector Pinouts

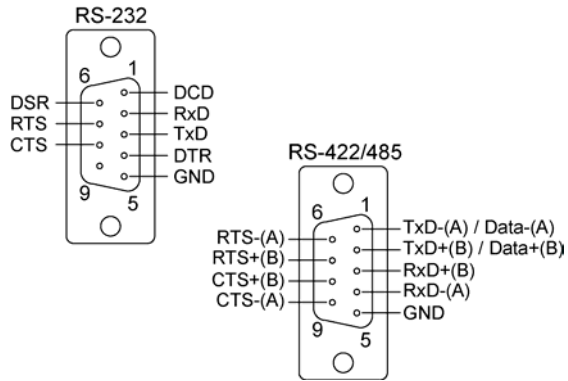

RS-232 Wiring

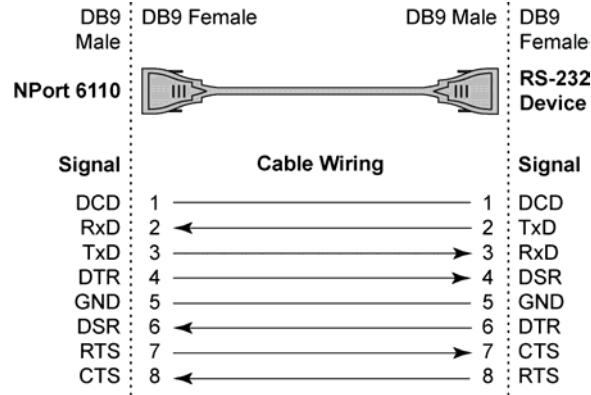
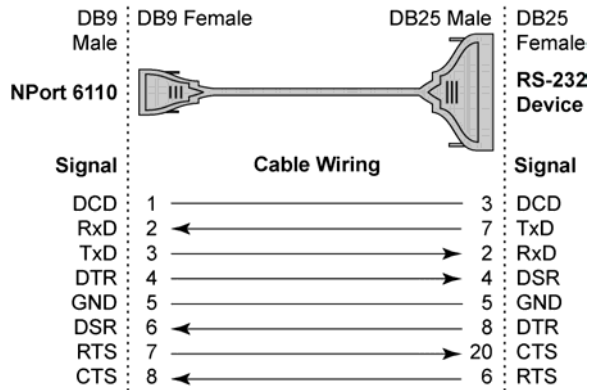

RS-422 Wiring

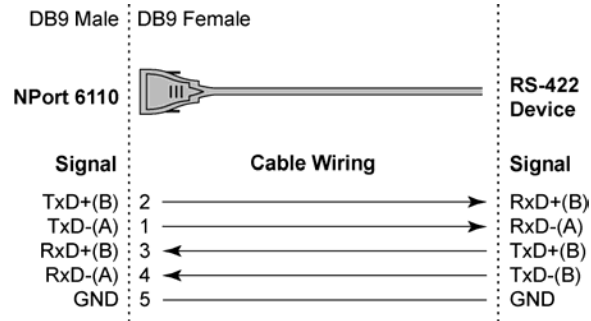

RS-485 Wiring

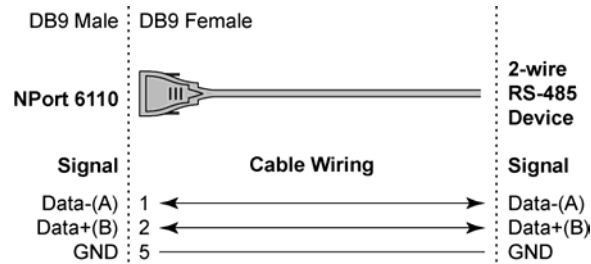

7. Environmental Specifications

Power requirements	9 to 30 VDC, 300 mA at 12V (max.)
Operating temp.	0 to 55°C (32 to 131°F)
Operating humidity	5 to 95% RH
Dimensions (W×D×H)	90 × 100.4 × 22 mm (including ears)
	3.54 × 3.95 × 0.87 in (including ears)
	67 × 100.4 × 22 mm (without ears)
Surge protection	15 KV ESD for serial port
Magnetic isolation	1.5 KV for Ethernet
Regulatory approvals	FCC B, CE B, UL, CUL, TÜV

Copyright © 2004
 Moxa Technologies Co., Ltd.
 All rights reserved.
 Reproduction without permission is prohibited.

 Tel: +886-2-8919-1230
 Fax: +886-2-8919-1231
 www.moxa.com
 support@moxa.com.tw
