

# PT-508 Series

## IEC 61850-3 8-port Layer 2 DIN-rail managed Ethernet switches



### Features and Benefits

- IEC 61850-3 and IEEE 1613 compliant
- Turbo Ring and Turbo Chain (recovery time < 20 ms @ 250 switches), and STP/RSTP/MSTP for network redundancy
- Easy network management by web browser, CLI, Telnet/serial console, Windows utility, and ABC-01
- Isolated universal 24 VDC or 48 VDC redundant power inputs
- Wide 110/220 VDC/VAC power supply range
- Modbus TCP, LLDP, SNMP Inform, QoS, IGMP snooping, VLAN, IEEE 802.1X, HTTPS, SNMPv3, and SSH supported
- -40 to 85°C operating temperature range

### Certifications



## Introduction

The PowerTrans PT-508 Series is designed to meet the demands of power substation automation systems (IEC 61850-3, IEEE 1613). The PT-508's optical fiber Fast Ethernet backbone, redundant ring, redundant power inputs (24 VDC or 48 VDC), and isolated power inputs (24 VDC, 48 VDC, or 110/220 VDC/VAC) increase the reliability of your communications and save on cabling/wiring costs. In addition, the DIN-rail and wall-mounting design of the PT-508 switches simplify network planning, and allows greater flexibility by letting you install up to 8 Fast Ethernet ports for power distribution applications.

### Additional Features and Benefits

- Command line interface (CLI) for quickly configuring major managed functions
- VLAN Unaware: Supports priority-tagged frames to be received by specific IEDs
- EtherNet/IP and Modbus TCP industrial Ethernet protocols supported
- Configurable by web browser, Telnet/Serial console, CLI, Windows utility, and ABC-02 automatic backup configurator
- DHCP Option 82 for IP address assignment with different policies
- IGMP snooping and GMRP for filtering multicast traffic from industrial Ethernet protocols
- IEEE 802.3ad, LACP for optimum bandwidth utilization
- Bandwidth management to prevent unpredictable network status
- Multi-port mirroring for online debugging
- Automatic warning by exception through email and relay output
- RMON for proactive and efficient network monitoring
- Automatic recovery of connected device's IP addresses
- Line-swap fast recovery

### Cybersecurity Features

- User passwords with multiple levels of security protect against unauthorized configuration
- SSH/HTTPS is used to encrypt passwords and data
- Lock switch ports with 802.1X port-based network access control so that only authorized clients can access the port
- RADIUS/TACACS+ allows you to manage passwords from a central location
- 802.1Q VLAN allows you to logically partition traffic transmitted between selected switch ports
- Secure switch ports so that only specific devices and/or MAC addresses can access the ports
- Disable one or more ports to block network traffic
- SNMPv3 provides encrypted authentication and access security

## Specifications

### Ethernet Interface

10/100BaseT(X) Ports (RJ45 connector)	6
100BaseFX Ports (multi-mode SC connector)	PT-508-MM-SC Series: 2
100BaseFX Ports (multi-mode ST connector)	PT-508-MM-ST Series: 2

100BaseFX Ports (single-mode SC connector)	PT-508-SS-SC Series: 2
100BaseFX Ports (multi-mode LC connector)	PT-508-MM-LC Series: 2
100BaseFX Ports (single-mode LC connector)	PT-508-SS-LC Series: 2

Optical Fiber		100BaseFX		
		Multi-Mode		Single-Mode
		Fiber Cable Type	OM1	50/125 μm
			800 MHz x km	
Typical Distance		4 km	5 km	40 km
Wavelength	Typical (nm)	1300		1310
	TX Range (nm)	1260 to 1360		1280 to 1340
	RX Range (nm)	1100 to 1600		1100 to 1600
Optical Power	TX Range (dBm)	-10 to -20		0 to -5
	RX Range (dBm)	-3 to -32		-3 to -34
	Link Budget (dB)	12		29
	Dispersion Penalty (dB)	3		1
<p>Note: When connecting a single-mode fiber transceiver, we recommend using an attenuator to prevent damage caused by excessive optical power.</p> <p>Note: Compute the “typical distance” of a specific fiber transceiver as follows: Link budget (dB) &gt; dispersion penalty (dB) + total link loss (dB).</p>				

Standards	IEEE 802.1D-2004 for Spanning Tree Protocol IEEE 802.1p for Class of Service IEEE 802.1Q for VLAN Tagging IEEE 802.1s for Multiple Spanning Tree Protocol IEEE 802.1w for Rapid Spanning Tree Protocol IEEE 802.1X for authentication IEEE 802.3 for 10BaseT IEEE 802.3ab for 1000BaseT(X) IEEE 802.3ad for Port Trunk with LACP IEEE 802.3u for 100BaseT(X) and 100BaseFX IEEE 802.3x for flow control
-----------	---

### Ethernet Software Features

Filter	802.1Q, GMRP, GVRP, IGMP v1/v2c, Port-based VLAN, VLAN unaware
Industrial Protocols	EtherNet/IP, Modbus TCP
Management	Back Pressure Flow Control, BOOTP, DHCP Option 66/67/82, DHCP Server/Client, Flow control, HTTP, IPv4/IPv6, LLDP, Port Mirror, RARP, RMON, SMTP, SNMP Inform, SNMPv1/v2c/v3, Syslog, Telnet, TFTP
MIB	Bridge MIB, Ethernet-like MIB, MIB-II, P-BRIDGE MIB, Q-BRIDGE MIB, RMON MIB Groups 1, 2, 3, 9, RSTP MIB
Redundancy Protocols	Link Aggregation, MSTP, RSTP, STP, Turbo Chain, Turbo Ring v1/v2
Security	HTTPS/SSL, TACACS+, Port Lock, RADIUS, Rate Limit, SSH
Time Management	NTP Server/Client, SNTP, 100BaseFX Single-Mode

### Switch Properties

IGMP Groups	256
MAC Table Size	8 K

Max. No. of VLANs	64
Packet Buffer Size	1 Mbits
VLAN ID Range	VID 1 to 4094
Priority Queues	4
<b>Serial Interface</b>	
Console Port	RS-232 (RJ45)
<b>Input/Output Interface</b>	
Alarm Contact Channels	Resistive load: 1 A @ 24 VDC
<b>Power Parameters</b>	
Connection	1 removable 5-contact terminal block(s)
Input Voltage	PT-508-24/48 Series: Redundant power inputs PT-508-24 Series: 24 VDC (18 to 36 VDC) PT-508-48 Series: 48 VDC (36 to 72 VDC) PT-508-HV Series: 110/220 VAC/VDC (88 to 300 VAC, 85 to 264 VDC)
Overload Current Protection	Supported
Reverse Polarity Protection	Supported
Input Current	PT-508-24 Series: 0.27 A @ 24 VDC PT-508-48 Series: 0.12 A @ 48 VDC PT-508-HV Series: 0.18/0.11 A @ 110/220 VAC, 0.084/0.043 A @ 110/220 VDC
<b>Physical Characteristics</b>	
Housing	Aluminum
IP Rating	IP40
Dimensions (without ears)	60 x 160 x 110 mm (2.36 x 6.30 x 4.33 in)
Weight	995 g (2.21 lb)
Installation	DIN-rail mounting, DIN-rail mounting (with optional kit)
<b>Environmental Limits</b>	
Operating Temperature	-40 to 85°C (-40 to 185°F) Note: Cold start requires minimum of 100 VAC @ -40°C
Storage Temperature (package included)	-40 to 85°C (-40 to 185°F)
Ambient Relative Humidity	5 to 95% (non-condensing)
<b>Standards and Certifications</b>	
EMI	EN 55032 Class A, CISPR 32, FCC Part 15B Class A
EMS	IEC 61000-4-2 ESD: Contact: 8 kV; Air: 15 kV IEC 61000-4-3 RS: 80 MHz to 1 GHz: 20 V/m IEC 61000-4-4 EFT: Power: 4 kV; Signal: 4 kV IEC 61000-4-5 Surge: Power: 4 kV; Signal: 4 kV IEC 61000-4-6 CS: 10 V IEC 61000-4-8 PFMF IEC 61000-4-11 DIPs
Power Substation	IEC 61850-3, IEEE 1613
Safety	UL 508

## MTBF

Time	394,238 hrs
Standards	Telcordia SR332

## Warranty

Warranty Period	5 years
Details	See <a href="http://www.moxa.com/warranty">www.moxa.com/warranty</a>

## Package Contents

Device	1 x PT-508 Series switch
Cable	1 x DB9 female to RJ45 10-pin 1 x grounding cable
Installation Kit	1 x DIN-rail kit 2 x cap, plastic, for SC fiber port (PT-508-SC Series) 2 x cap, plastic, for ST fiber port (PT-508-ST Series) 2 x cap, plastic, for LC fiber port (PT-508-LC Series) 11 x cap, plastic, for RJ45 port
Documentation	1 x document and software CD 1 x quick installation guide 1 x warranty card 1 x product certificates of quality inspection, Simplified Chinese 1 x product notice, Simplified Chinese

## Dimensions

Unit: mm (inch)

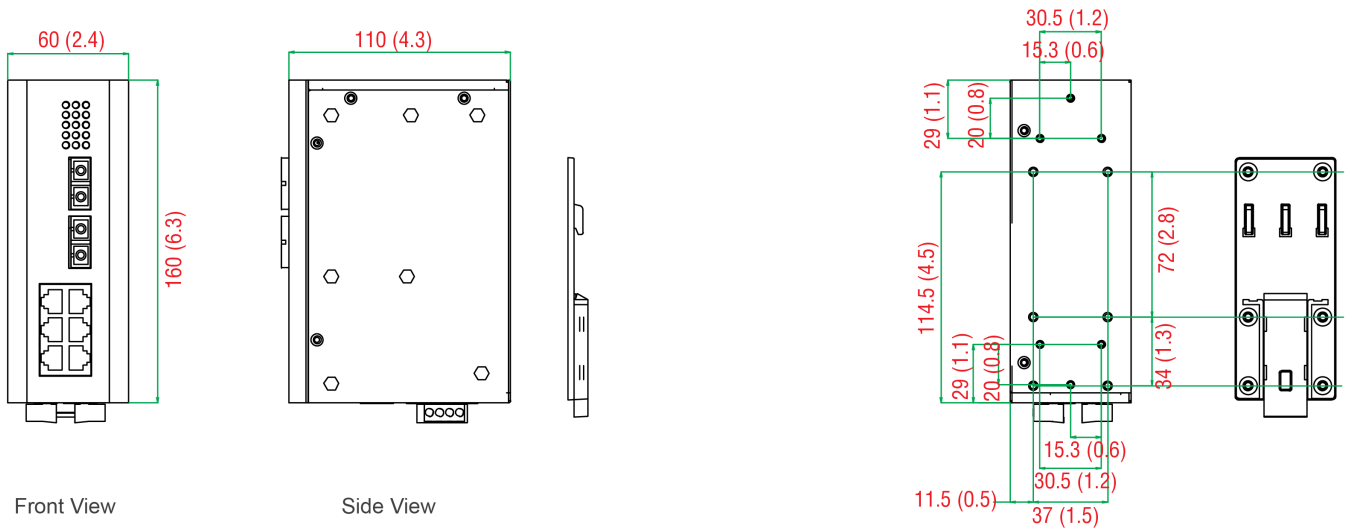

DIN-Rail Mounting Kit

## Ordering Information

Model Name	10/ 100BaseT(X)	100BaseFX Single-Mode Ports with SC Connector	100BaseFX Multi-Mode Ports with SC Connector	100BaseFX Multi-Mode Ports with ST Connector	100BaseFX Single-Mode Ports with LC Connector	100BaseFX Multi-Mode Ports with LC Connector	Operating Temp.	Input Voltage
PT-508-SS-SC-24	6	2	-	-	-	-	-45 to 85°C	24 VDC
PT-508-SS-SC-48	6	2	-	-	-	-	-45 to 85°C	48 VDC
PT-508-MM-ST-HV	6	-	-	2	-	-	-45 to 85°C	110/220 VDC/ VAC

Model Name	10/ 100BaseT(X)	100BaseFX Single-Mode Ports with SC Connector	100BaseFX Multi-Mode Ports with SC Connector	100BaseFX Multi-Mode Ports with ST Connector	100BaseFX Single-Mode Ports with LC Connector	100BaseFX Multi-Mode Ports with LC Connector	Operating Temp.	Input Voltage
PT-508-MM-SC-24	6	–	2	–	–	–	-45 to 85°C	24 VDC
PT-508-SS-SC-HV	6	2	–	–	–	–	-45 to 85°C	110/220 VDC/ VAC
PT-508-MM-SC-48	6	–	2	–	–	–	-45 to 85°C	48 VDC
PT-508-MM-ST-24	6	–	–	2	–	–	-45 to 85°C	24 VDC
PT-508-MM-ST-48	6	–	–	2	–	–	-45 to 85°C	48 VDC
PT-508-MM-SC- HV	6	–	2	–	–	–	-45 to 85°C	110/220 VDC/ VAC
PT-508-SS-LC-24	6	–	–	–	2	–	-45 to 85°C	24 VDC
PT-508-SS-LC-48	6	–	–	–	2	–	-45 to 85°C	48 VDC
PT-508-MM-LC-24	6	–	–	–	–	2	-45 to 85°C	24 VDC
PT-508-MM-LC-48	6	–	–	–	–	2	-45 to 85°C	48 VDC
PT-508-MM-LC-HV	6	–	–	–	–	2	-45 to 85°C	110/220 VDC/ VAC
PT-508-SS-LC-HV	6	–	–	–	2	–	-45 to 85°C	110/220 VDC/ VAC

## Accessories (sold separately)

### Software

MXview-50	Industrial network management software with a license for 50 nodes (by IP address)
MXview-100	Industrial network management software with a license for 100 nodes (by IP address)
MXview-250	Industrial network management software with a license for 250 nodes (by IP address)
MXview-500	Industrial network management software with a license for 500 nodes (by IP address)
MXview-1000	Industrial network management software with a license for 1000 nodes (by IP address)
MXview-2000	Industrial network management software with a license for 2000 nodes (by IP address)
MXview Upgrade-50	License expansion of MXview industrial network management software by 50 nodes (by IP address)

### Storage Kits

ABC-01	Configuration backup and restoration tool for managed Ethernet switches and AWK Series wireless APs/bridges/clients, 0 to 60°C operating temperature
--------	--

© Moxa Inc. All rights reserved. Updated Jun 18, 2019.

This document and any portion thereof may not be reproduced or used in any manner whatsoever without the express written permission of Moxa Inc. Product specifications subject to change without notice. Visit our website for the most up-to-date product information.