

# AWK-3131A-RCCシリーズ

## 鉄道車両向けのWi-Fi 4 (802.11n) IP30無線AP/クライアント



### 機能とメリット

- 車両間ワイヤレス接続を実現する車両間自動接続 (ACC) 機能
- 最大60台の同時デバイス接続とクライアントアイソレーションをサポート
- 150 ms未満のクライアントベースTurbo Roamingにより、シームレスなデータオフロードを実現

### 認証



EN 50155



EN 50121-4



### 製品紹介

AWK-3131A-RCCシリーズは、鉄道車載用に設計されたIP30保護等級のWi-Fi 4 (802.11n) AP/クライアントであり、車両間バックボーンネットワークや車載乗客向けインフォテインメントシステムなどの専用アプリケーションに信頼性の高い無線ソリューションを提供します。車両間自動接続 (ACC) 機能により、導入の簡素化を可能にし、無線車両間バックボーンネットワークの信頼性を高めます。乗客Wi-Fiサービス向けに最適化されており、最大60台のクライアント接続と最大300 Mbpsのデータレートをサポートします。さらに、PoE給電が可能なため、設置が容易で柔軟な導入が実現できます。

### 仕様

#### WLAN Interface

WLAN Standards	2.4 GHz: 802.11b/g/n with 64 QAM support, 20/40 MHz 5 GHz: 802.11a/n with 64 QAM support, 20/40 MHz
Frequency Band for US (20 MHz operating channels)	AWK-3131A-RCC-US models: 2.412 to 2.462 GHz (11 channels) 5.180 to 5.240 GHz (4 channels) 5.260 to 5.320 GHz (4 channels) <sup>1</sup> 5.500 to 5.700 GHz (8 channels) excluding 5.600 to 5.640 GHz <sup>1</sup> 5.745 to 5.825 GHz (5 channels)
Frequency Band for EU (20 MHz operating channels)	AWK-3131A-RCC-EU models only: 2.412 to 2.472 GHz (13 channels) 5.180 to 5.240 GHz (4 channels) 5.260 to 5.320 GHz (4 channels) <sup>1</sup> 5.500 to 5.700 GHz (11 channels) <sup>1</sup>
Frequency Band for JP (20 MHz operating channels)	AWK-3131A-RCC-JP models only: 2.412 to 2.484 GHz (14 channels) 5.180 to 5.240 GHz (4 channels) 5.260 to 5.320 GHz (4 channels) <sup>1</sup> 5.500 to 5.700 GHz (11 channels) <sup>1</sup>
Wireless Security	SSID broadcast enable/disable, WEP encryption (64-bit and 128-bit), WPA/WPA2-Enterprise (IEEE 802.1X/RADIUS, TKIP, AES), WPA/WPA2-Personal
Transmission Rate	802.11b: 1 to 11 Mbps, 802.11a/g: 6 to 54 Mbps, 802.11n: 6.5 to 300 Mbps

1. DFS (Dynamic Frequency Selection/動的周波数選択) チャンネル対応: APモードでは、レーダー信号が検出された場合、自動的に別のチャンネルへ切り替わります。ただし、規制により、チャンネル切り替え後、サービス開始前には60秒間の利用可能性確認期間が必要です。

Transmitter Power for 802.11a	23±1.5 dBm @ 6 to 24 Mbps, 21±1.5 dBm @ 36 Mbps, 20±1.5 dBm @ 48 Mbps, 18±1.5 dBm @ 54 Mbps
Transmitter Power for 802.11n (5 GHz)	23±1.5 dBm @ MCS0 20 MHz, 20±1.5 dBm @ MCS1 20 MHz, 20±1.5 dBm @ MCS2 20 MHz, 20±1.5 dBm @ MCS3 20 MHz, 19±1.5 dBm @ MCS4 20 MHz, 18±1.5 dBm @ MCS5 20 MHz, 18±1.5 dBm @ MCS6 20 MHz, 18±1.5 dBm @ MCS7 20 MHz, 23±1.5 dBm @ MCS8 20 MHz, 20±1.5 dBm @ MCS9 20 MHz, 20±1.5 dBm @ MCS10 20 MHz, 20±1.5 dBm @ MCS11 20 MHz, 19±1.5 dBm @ MCS12 20 MHz, 19±1.5 dBm @ MCS13 20 MHz, 18±1.5 dBm @ MCS14 20 MHz, 18±1.5 dBm @ MCS15 20 MHz, 23±1.5 dBm @ MCS0 40 MHz, 20±1.5 dBm @ MCS1 40 MHz, 20±1.5 dBm @ MCS2 40 MHz, 20±1.5 dBm @ MCS3 40 MHz, 19±1.5 dBm @ MCS4 40 MHz, 18±1.5 dBm @ MCS5 40 MHz, 18±1.5 dBm @ MCS6 40 MHz, 18±1.5 dBm @ MCS7 40 MHz, 23±1.5 dBm @ MCS8 40 MHz, 20±1.5 dBm @ MCS9 40 MHz, 20±1.5 dBm @ MCS10 40 MHz, 20±1.5 dBm @ MCS11 40 MHz, 19±1.5 dBm @ MCS12 40 MHz, 19±1.5 dBm @ MCS13 40 MHz, 18±1.5 dBm @ MCS14 40 MHz, 18±1.5 dBm @ MCS15 40 MHz
Transmitter Power for 802.11b	26±1.5 dBm @ 1 Mbps, 26±1.5 dBm @ 2 Mbps, 26±1.5 dBm @ 5.5 Mbps, 25±1.5 dBm @ 11 Mbps
Transmitter Power for 802.11g	23±1.5 dBm @ 6 to 24 Mbps, 21±1.5 dBm @ 36 Mbps, 19±1.5 dBm @ 48 Mbps, 18±1.5 dBm @ 54 Mbps
Transmitter Power for 802.11n (2.4 GHz)	23±1.5 dBm @ MCS0 20 MHz, 21±1.5 dBm @ MCS1 20 MHz, 21±1.5 dBm @ MCS2 20 MHz, 21±1.5 dBm @ MCS3 20 MHz, 20±1.5 dBm @ MCS4 20 MHz, 19±1.5 dBm @ MCS5 20 MHz, 18±1.5 dBm @ MCS6 20 MHz, 18±1.5 dBm @ MCS7 20 MHz, 23±1.5 dBm @ MCS8 20 MHz, 21±1.5 dBm @ MCS9 20 MHz, 21±1.5 dBm @ MCS10 20 MHz, 21±1.5 dBm @ MCS11 20 MHz, 20±1.5 dBm @ MCS12 20 MHz, 19±1.5 dBm @ MCS13 20 MHz, 18±1.5 dBm @ MCS14 20 MHz, 18±1.5 dBm @ MCS15 20 MHz, 23±1.5 dBm @ MCS0 40 MHz, 20±1.5 dBm @ MCS1 40 MHz, 20±1.5 dBm @ MCS2 40 MHz, 20±1.5 dBm @ MCS3 40 MHz, 19±1.5 dBm @ MCS4 40 MHz, 19±1.5 dBm @ MCS5 40 MHz, 18±1.5 dBm @ MCS6 40 MHz, 17±1.5 dBm @ MCS7 40 MHz, 23±1.5 dBm @ MCS8 40 MHz, 20±1.5 dBm @ MCS9 40 MHz, 20±1.5 dBm @ MCS10 40 MHz, 20±1.5 dBm @ MCS11 40 MHz, 20±1.5 dBm @ MCS12 40 MHz, 19±1.5 dBm @ MCS13 40 MHz, 18±1.5 dBm @ MCS14 40 MHz, 17±1.5 dBm @ MCS15 40 MHz
Receiver Sensitivity for 802.11a (measured at 5.680 GHz)	Typ. -90 @ 6 Mbps, Typ. -88 @ 9 Mbps, Typ. -88 @ 12 Mbps, Typ. -85 @ 18 Mbps, Typ. -81 @ 24 Mbps, Typ. -78 @ 36 Mbps, Typ. -74 @ 48 Mbps, Typ. -74 @ 54 Mbps, Note: Due to a limitation in the receiver sensitivity performance for channels 153 and 161, it is recommended to avoid using these channels in your critical applications.
Receiver Sensitivity for 802.11n (5 GHz; measured at 5.680 GHz)	Typ. -88 dBm @ MCS0 20 MHz, Typ. -85 dBm @ MCS1 20 MHz, Typ. -82 dBm @ MCS2 20 MHz, Typ. -79 dBm @ MCS3 20 MHz, Typ. -76 dBm @ MCS4 20 MHz, Typ. -71 dBm @ MCS5 20 MHz, Typ. -70 dBm @ MCS6 20 MHz, Typ. -69 dBm @ MCS7 20 MHz, Typ. -95 dBm @ MCS8 20 MHz, Typ. -91 dBm @ MCS9 20 MHz, Typ. -87 dBm @ MCS10 20 MHz, Typ. -80 dBm @ MCS11 20 MHz, Typ. -78 dBm @ MCS12 20 MHz, Typ. -74 dBm @ MCS13 20 MHz, Typ. -72 dBm @ MCS14 20 MHz, Typ. -71 dBm @ MCS15 20 MHz, Typ. -84 dBm @ MCS0 40 MHz, Typ. -81 dBm @ MCS1 40 MHz, Typ. -77 dBm @ MCS2 40 MHz, Typ. -75 dBm @ MCS3 40 MHz, Typ. -71 dBm @ MCS4 40 MHz, Typ. -67 dBm @ MCS5 40 MHz, Typ. -64 dBm @ MCS6 40 MHz, Typ. -63 dBm @ MCS7 40 MHz, Typ. -90 dBm @ MCS8 40 MHz, Typ. -85 dBm @ MCS9 40 MHz, Typ. -82 dBm @ MCS10 40 MHz, Typ. -81 dBm @ MCS11 40 MHz, Typ. -77 dBm @ MCS12 40 MHz, Typ. -73 dBm @ MCS13 40 MHz, Typ. -71 dBm @ MCS14 40 MHz, Typ. -68 dBm @ MCS15 40 MHz, Note: Due to a limitation in the receiver sensitivity performance for channels 153 and 161, it is recommended to avoid using these channels in your critical applications.
Receiver Sensitivity for 802.11b (measured at 2.437 GHz)	Typ. -93 dBm @ 1 Mbps, Typ. -93 dBm @ 2 Mbps, Typ. -93 dBm @ 5.5 Mbps, Typ. -88 dBm @ 11 Mbps
Receiver Sensitivity for 802.11g (measured at 2.437 GHz)	Typ. -88 dBm @ 6 Mbps, Typ. -86 dBm @ 9 Mbps, Typ. -85 dBm @ 12 Mbps, Typ. -85 dBm @ 18 Mbps, Typ. -85 dBm @ 24 Mbps, Typ. -82 dBm @ 36 Mbps, Typ. -78 dBm @ 48 Mbps, Typ. -74 dBm @ 54 Mbps
Receiver Sensitivity for 802.11n (2.4 GHz; measured at 2.437 GHz)	Typ. -89 dBm @ MCS0 20 MHz, Typ. -85 dBm @ MCS1 20 MHz, Typ. -85 dBm @ MCS2 20 MHz, Typ. -82 dBm @ MCS3 20 MHz, Typ. -78 dBm @ MCS4 20 MHz, Typ. -74 dBm @ MCS5 20 MHz, Typ. -72 dBm @ MCS6 20 MHz, Typ. -70 dBm @ MCS7 20 MHz, Typ. -95 dBm @ MCS8 20 MHz, Typ. -90 dBm @ MCS9 20 MHz, Typ. -87 dBm @ MCS10 20 MHz, Typ. -83 dBm @ MCS11 20 MHz, Typ. -80 dBm @ MCS12 20 MHz, Typ. -74 dBm @ MCS13 20 MHz, Typ. -71 dBm @ MCS14 20 MHz, Typ. -69 dBm @ MCS15 20 MHz, Typ. -87 dBm @ MCS0 40 MHz, Typ. -83 dBm @ MCS1 40 MHz, Typ. -83 dBm @ MCS2 40 MHz, Typ. -80 dBm @ MCS3 40 MHz, Typ. -76 dBm @ MCS4 40 MHz, Typ. -73 dBm @ MCS5 40 MHz, Typ. -69 dBm @ MCS6 40 MHz, Typ. -67 dBm @ MCS7 40 MHz, Typ. -93 dBm @ MCS8 40 MHz, Typ. -88 dBm @ MCS9 40 MHz, Typ. -85 dBm @ MCS10 40 MHz,

	Typ. -82 dBm @ MCS11 40 MHz, Typ. -78 dBm @ MCS12 40 MHz, Typ. -73 dBm @ MCS13 40 MHz, Typ. -69 dBm @ MCS14 40 MHz, Typ. -67 dBm @ MCS15 40 MHz
WLAN Operation Mode	Access point, Client, Client-Router, Sniffer
Antenna Connectors	2 x QMA
<b>Ethernet Interface</b>	
Standards	IEEE 802.3 for 10BaseT, IEEE 802.3u for 100BaseT(X), IEEE 802.3ab for 1000BaseT, IEEE 802.3af for PoE, IEEE 802.1Q for VLAN Tagging
10/100/1000BaseT(X) Ports (M12 A-coded 8-pin female connector)	1 Supports IEEE 802.3af PoE
<b>Ethernet Software Features</b>	
Management	SNMPv1/v2c/v3, Proxy ARP, ARP, DNS, HTTP, HTTPS, ICMP, TCP/IP, UDP, RADIUS, DHCP, BOOTP
Security	RADIUS
Time Management	SNTP
<b>Firewall</b>	
Filter	IP protocol, Port-based, MAC address
<b>Serial Interface</b>	
Console Port	RS-232 (RJ45-type)
<b>LED Interface</b>	
LED Indicators	PWR1, PWR2, PoE, FAULT, STATE, SIGNAL, Client, WLAN, LAN
<b>Input/Output Interface</b>	
Digital Inputs	2, +13 to +30 V for state 1, +3 to -30 V for state 0, Max. input current: 8 mA
Alarm Contact Channels	Relay output with current carrying capacity of 1 A @ 24 VDC
Buttons	Reset button
<b>Physical Characteristics</b>	
Housing	Metal
IP Rating	IP30
Dimensions	52.9 x 151.9 x 127.4 mm (2.08 x 5.98 x 5.02 in)
Weight	850 g (1.87 lb)
Installation	DIN-rail mounting, Wall mounting (with optional kit)
Protection	-CT models: PCB conformal coating
<b>Power Parameters</b>	
Input Current	0.67 A @ 12 VDC, 0.17 A @ 48 VDC
Input Voltage	12 to 48 VDC, Redundant dual inputs, 48 VDC Power over Ethernet
Power Connector	1 removable 10-contact terminal block(s)
Power Consumption	8.03 W (max.)
Reverse Polarity Protection	Supported

## Environmental Limits

Operating Temperature	Standard models: -25 to 60°C (-13 to 140°F) Wide temp. models: -40 to 75°C (-40 to 167°F)
Storage Temperature (package included)	-40 to 85°C (-40 to 185°F)
Ambient Relative Humidity	5 to 95% (non-condensing)

## Standards and Certifications

EMC	EN 55032/24
EMI	CISPR 32, FCC Part 15B Class B
EMS	IEC 61000-4-2 ESD: Contact: 8 kV; Air: 15 kV, IEC 61000-4-3 RS: 80 MHz to 1 GHz: 20 V/m, IEC 61000-4-4 EFT: Power: 2 kV; Signal: 2 kV, IEC 61000-4-5 Surge: Power: 2 kV; Signal: 2 kV, IEC 61000-4-6 CS: 10 V, IEC 61000-4-8 PFMF
Railway	EN 50155, EN 50121-4
Railway Fire Protection	EN 45545-2
Radio	EN 300 328, EN 301 893, MIC, FCC ID SLE-WAPN008, IDA
Safety	UL 60950-1, IEC 60950-1, EN 60950-1 (LVD)

## MTBF

Time	742,649 hrs
Standards	Telcordia Standard SR-332

## Warranty

Warranty Period	5 years
Details	See <a href="http://www.moxa.com/jp/warranty">www.moxa.com/jp/warranty</a>

## Package Contents

Device	1 x AWK-3131A-M12-RCC wireless AP/client
Installation Kit	1 x DIN-rail kit, 2 x cap, plastic, for RJ45 port, 1 x cable holder with screw
Documentation	1 x quick installation guide, 1 x warranty card

## 寸法

単位：mm（インチ）

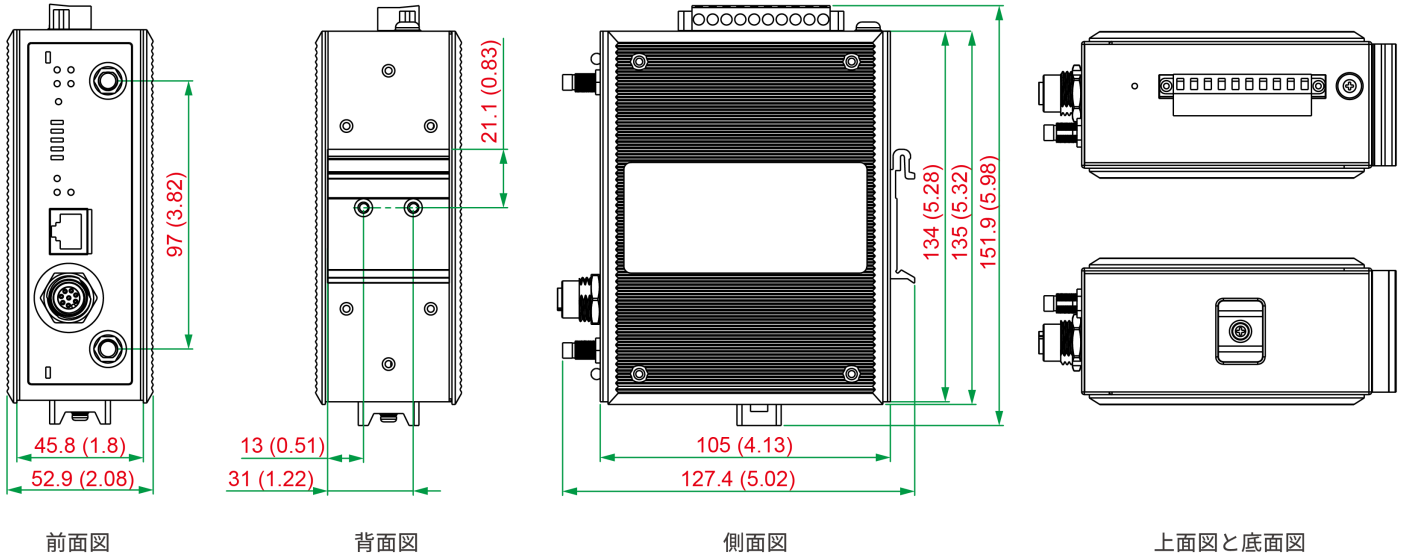

## 注文情報

Model Name	Band	Operating Temperature (-40 to 75°C)	Conformal Coating
AWK-3131A-M12-RCC-US	US	-25 to 60°C	-
AWK-3131A-M12-RCC-EU	EU	-25 to 60°C	-
AWK-3131A-M12-RCC-JP	JP	-25 to 60°C	-
AWK-3131A-M12-RCC-US-T	US	-40 to 75°C	-
AWK-3131A-M12-RCC-EU-T	EU	-40 to 75°C	-
AWK-3131A-M12-RCC-JP-T	JP	-40 to 75°C	-
AWK-3131A-M12-RCC-US-CT	US	-25 to 60°C	P
AWK-3131A-M12-RCC-EU-CT	EU	-25 to 60°C	P
AWK-3131A-M12-RCC-JP-CT	JP	-25 to 60°C	P
AWK-3131A-M12-RCC-US-CT-T	US	-40 to 75°C	P
AWK-3131A-M12-RCC-EU-CT-T	EU	-40 to 75°C	P
AWK-3131A-M12-RCC-JP-CT-T	JP	-40 to 75°C	P

## アクセサリ（別売）

### Wall-Mounting Kits

WK-51-01 Wall mounting kit with 2 plates (51.6 x 67 x 2 mm) and 6 screws

© Moxa Inc. All rights reserved. 2026年1月23日更新。

Moxa Inc.の明白な許可を written で取得しない限り、本書およびその一部の複製や使用はいかなる方法やいかなる場合でも許可されません。製品の仕様は予告なく変更されることがあります。最新の製品情報については当社のWebサイトをご覧ください。