

# **VPort 07-3 Series Quick Installation Guide**

---

**Moxa IP Camera**

**Version 1.0, November 2024**

**Technical Support Contact Information**  
**[www.moxa.com/support](http://www.moxa.com/support)**

**MOXA®**

© 2024 Moxa Inc. All rights reserved.

**P/N: 1802000070010**



## Overview

The VPort 07-3 Series is a compact IP dome camera that supports a maximum 2048 x 1536 video image at 20 frames per second or 1920 x 1080 video at 30 frames per second, and H.265/H.264/MJPEG. It is designed for mobile video surveillance applications and features EN 50155 compliance, vandal-proofing (EN 62262 IK8), operating temperature of -40 to 55°C or -40 to 70°C (T model), rugged M12 Ethernet port, 1 audio input or built-in microphone, PoE or 24 VDC power inputs, IP66 rain and dust protection, dehumidifying membrane, and selectable lens models, for the versatility and ruggedness required to excel in many different installations and environments for mobile IP video surveillance applications.

## Ordering Information

The following VPort 07-3 Series models are available:

Model		Lens (mm)	Audio	Temperature	
PoE model	24 VDC model			-40 to 55°C	-40 to 70°C
VPort P07-3L24M	VPort 07-3L24M	2.4	Line-in	✓	-
VPort P07-3L36M	VPort 07-3L36M	3.6	Line-in	✓	-
VPort P07-3L42M	VPort 07-3L42M	4.2	Line-in	✓	-
VPort P07-3L60M	VPort 07-3L60M	6	Line-in	✓	-
VPort P07-3L80M	VPort 07-3L80M	8	Line-in	✓	-
VPort P07-3M24M	VPort 07-3M24M	2.4	Mic-in	✓	-
VPort P07-3M36M	VPort 07-3M36M	3.6	Mic-in	✓	-
VPort P07-3M42M	VPort 07-3M42M	4.2	Mic-in	✓	-
VPort P07-3M60M	VPort 07-3M60M	6	Mic-in	✓	-
VPort P07-3M80M	VPort 07-3M80M	8	Mic-in	✓	-
VPort P07-3L24M-T	VPort 07-3L24M-T	2.4	Line-in	-	✓
VPort P07-3L36M-T	VPort 07-3L36M-T	3.6	Line-in	-	✓
VPort P07-3L42M-T	VPort 07-3L42M-T	4.2	Line-in	-	✓
VPort P07-3L60M-T	VPort 07-3L60M-T	6	Line-in	-	✓
VPort P07-3L80M-T	VPort 07-3L80M-T	8	Line-in	-	✓
VPort P07-3M24M-T	VPort 07-3M24M-T	2.4	Mic-in	-	✓
VPort P07-3M36M-T	VPort 07-3M36M-T	3.6	Mic-in	-	✓
VPort P07-3M42M-T	VPort 07-3M42M-T	4.2	Mic-in	-	✓
VPort P07-3M60M-T	VPort 07-3M60M-T	6	Mic-in	-	✓
VPort P07-3M80M-T	VPort 07-3M80M-T	8	Mic-in	-	✓

### **Screw handle accessory package**

Torx screwdriver for attaching/detaching the upper case.	4 sets of nut, gasket, and spring washer for mounting the camera.	4 indented hexagonal head tapping screws for mounting the camera on the ceiling.
--	---	--

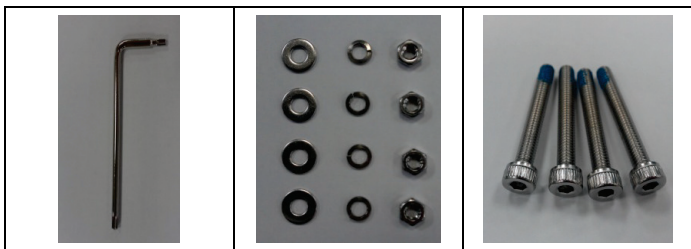

## Sticker for camera mounting positions

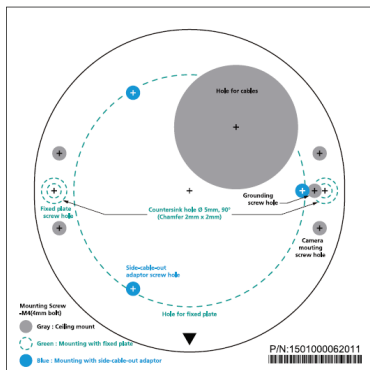

## Contents of the Package

- Quick installation guide (printed)
- Warranty card

**NOTE** Check the model name on the VPort's side label to determine if it is the correct one for your order.

**NOTE** This product must be installed in compliance with your local laws and regulations.

## Product Description

### Appearance

#### PoE-powered Models

5-pin M12 connector for digital input and audio input (line-in mode)



#### DC-powered Models

DB9 connector for digital input and audio input (line-in mode)



## All Models







- 4-pin D-coded female M12 Ethernet connector:** Can be used for both the PoE power supply (PoE model) and Auto MDI/MDI-X Ethernet connection

PIN	TX
1	TD+
2	RD+
3	TD-
4	RD-



**NOTE** To connect the VPort 07/P07-3MP Series to a network, use an Ethernet cable with D-code M12 connector and an M12 PoE switch or RJ45 PoE switch.

M12 D-code to M12 D-code cable 	M12 PoE switch (e.g., TN-5508-4PoE) 
M12 D-code and RJ45 cable 	RJ45 PoE switch (e.g., EDS-P510) 

**NOTE** The power input rating of the PoE model is 48 VDC, 0.137 A, with a maximum power consumption of approximately 6.6 W.

The power input rating of the DC models is 12 VDC, 0.59 A, with maximum power consumption of 7.1 W, and 24 VDC, 0.27 A with a maximum power consumption of 6.48 W.

**NOTE** The equipment is designed for indoor installation only and is not intended to be connected to exposed (outside the plant) networks.

- DB9 connector (24 VDC model):** Includes power input, digital input signal, and audio input (line-in model).

PIN	Con.
1	24 VDC +
2	NA
3	Audio +
4	NA
5	DI +
6	24 VDC return
7	NC
8	Audio -
9	DI -

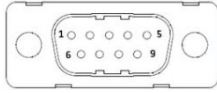

- **5-pin M12 connector (PoE model):** Includes digital input signal, and audio input (line-in model).

PIN	Con.
1	DI +
2	Line-in+
3	DI -
4	Line-in -
5	NA



- **Solid metal top cover:** This top cover can be removed for adjusting the camera lens position.
- **Transparent dome cover:** The VPort 07-3 Series is designed with a transparent PC dome cover, which is vandal-proof and satisfies EN 62262 (IEC 62262) Class IK8 requirements.
- **2 Torx screws for top cover:** These 2 torx screws are designed with anti-shedding to make installation more convenient. Use the L-type torx screwdriver to remove or attach the top cover.
- **Built-in microphone:** VPort 07-3M Series products have a built-in microphone, and can simultaneously display or record live video and audio.

**NOTE** The color of the form factor can be customized based on your installation environment. Please contact your Moxa sales representative for customization service.

### Inside the Camera

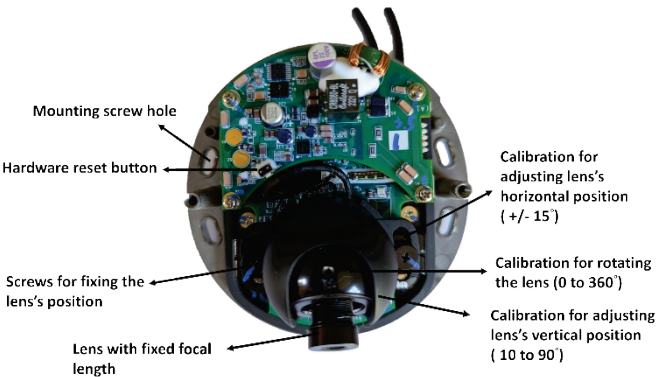

- **Mounting screw holes:** There are 4 mounting screw holes for mounting the VPort 07/P07-3 Series on the ceiling or the accessory.
- **Screw for fixing the lens's position:** To adjust the position of the lens, loosen the thumb screw, and then retighten it after you are done with adjusting the position of the lens.
- **Lens with fixed focal length:** The VPort 07/P07-3 Series includes models with 5 different focal lengths. Choose the appropriate focal length for your lens based on the viewing angle and object distance.
- **Hardware reset button:** The reset button is on the side of the camera's electronic board. Use a pointed object to depress the reset button to reboot or restore factory defaults.
  - Reboot: press the button once.
  - Factory default: press and hold the button for at least 10 sec.
- **Calibration for rotating lens (0 to 360°):** Rotate the lens to get the optimal image. When done, mark the position of this calibration for future placement or mass installation.
- **Calibration for adjusting lens's vertical position (10 to 90°):** After adjusting the lens's vertical position, mark the position of this calibration for future placement or mass installation.
- **Calibration for adjusting lens's horizontal position ( $\pm 15^\circ$ ):** After adjusting the lens's horizontal position, mark the position of this calibration for future placement or mass installation.

## Hardware Installation

**Step 1:** Open and remove the top cover.

Use the torx screwdriver to loosen the top cover screws and remove the dry pack that is in the camera.



**Step 2:** Use the markings on the installation sticker to position the drill bit before drilling holes. There are 3 types of installation.

**a. Mounting with 4 mounting screws**

To mount the camera on the ceiling, drill a hole through the gray portion of the sticker and then mount the camera with the 4 nut/gasket/spring-washer sets and the 4 indented hexagonal head tapping screws.

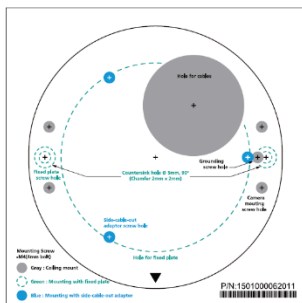

**NOTE** The 4 screws for mounting the VPort 07-3 or the fixed plate are M4 type with a 30 mm length thread.

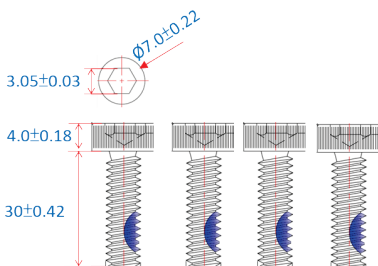

## b. Mounting with the side-cable-out adapter

Use the side-cable-out adapter (VP-SCO2) if your installation requires the cable-out on the side. Drill a hole through the blue portion of the sticker for mounting the adaptor on the surface with 3 nut/gasket/spring-washer sets and indented hexagonal head tapping screws. Then, mount the VPort 07-3 on the adapter with 4 M4 screws, which are provided in the VP-SCO2's package.

### VP-SCO2

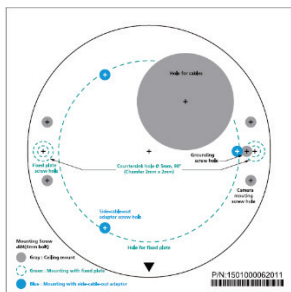
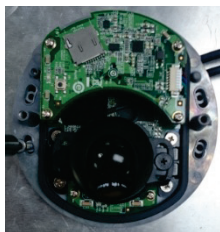

**NOTE** The 4 screws for mounting the VPort 07-3 onto the VP-SCO2 are M4 type with a 12 mm length thread.

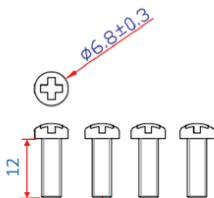

### c. Mounting with the fixed plate

If you cannot use the nut/gasket/spring-washer set to mount the camera on your ceiling, use the VP-FP2 fixed plate. Drill holes through the green dotted-line and 4 camera mounting screw markings on the sticker, and then place the VP-FP2 inside the hole. Use the 2 countersunk screws to mount the VP-FP2. Finally, mount the VPort 07/P07-3 Series on the fixed plate with the 4 indented hexagonal head tapping screws.

#### VP-FP2

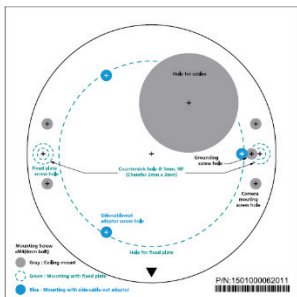

**NOTE** The screw hole for mounting the VP-FP2 fixed plate is a countersink hole with 5 mm diameter, and 90° 2 x 2 mm chamfer. Take this into consideration when drilling these 2 screw holes.



**NOTE** The 2 screws for mounting the VP-FP2 onto a ceiling are M4 type with a 16 mm length thread.

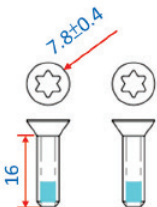

**Step 3:** Connect the camera with the 4-pin M12 D-code Ethernet connector and DB9 / 5-pin M12 connector.

**NOTE** Connectors used with the cameras should be IP66 compliant.

**Step 4:** Loosen the screw for adjusting the horizontal, vertical, and rotating lens position. Once the lens position is correct, fix the screw.

**NOTE** Make sure the thumb screw is loose enough when adjusting the lens holder. Moving the lens holder if the screw is too tight may affect the image focus of the lens.

**Step 5:** Fix the top cover. The installation is now complete.

- NOTE** 1. If required, a dry pack (VP-DP03) can be ordered separately to absorb moisture from the inside of the camera. Remove the dry pack from the package. Use the sticker on the dry pack to attach it to the inside of the top cover to absorb any moisture that has entered the camera housing during installation.

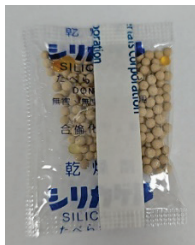

2. The dry pack may become saturated if exposed to air for too long. For this reason, reattach the top cover immediately after attaching the dry pack. If the cover is removed at any time in the future, be sure to replace the dry pack before reattaching the cover.

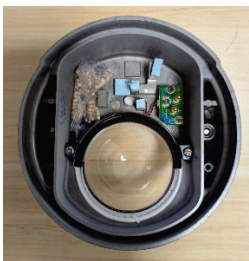

3. Make sure the top cover is attached tightly by placing the screws in the holes such that they can stay unaided, then tighten the screws in succession until they are all completely fastened
4. If a silica gel ball in the dry pack turns dark green, it means it is saturated with humidity. If all silica gel balls are dark green, the dry pack must be replaced with a new one.



## Grounding the VPort Camera

Grounding and wire routing help limit the effects of noise due to electromagnetic interference (EMI).

Run the ground connection from the grounding screw to the grounding surface prior to connecting devices.



### ATTENTION

This product is intended to be mounted to a well-grounded mounting surface such as a metal panel.

## Software Installation

**Step 1:** Configure the VPort 07-3's IP address.

When the VPort 07-3 Series is first powered on, the POST (Power On Self Test) will run for a few moments (about 150 seconds). The network environment determines how the IP address is assigned.

**NOTE** For security purpose, the VPort 07/P07-3 Series features a Secure Boot mechanism for validating the firmware, which results in an extended POST time of up to 150 seconds.

### Network Environment with DHCP Server

For this network environment, the unit's IP address will be assigned by the network's DHCP server. Refer to the DHCP server's IP address table to determine the unit's assigned IP address. You may also use the Moxa VPort and EtherDevice Configurator Utility (*edscfgui.exe*), as described below:

#### **Using the Moxa VPort and EtherDevice Configurator Utility (*edscfgui.exe*)**

1. Run the **edscfgui.exe** program to search for the VPort. After the utility's window opens, you may also click on the **Search** button  to initiate a search.
2. When the search has concluded, the Model Name, MAC address, IP address, serial port, and HTTP port of the VPort will be listed in the utility's window.

You can double click the selected VPort, or use the IE web browser to access the VPort's web-based manager (web server).

### Non DHCP Server Network Environment

If your VPort 07-3 Series is connected to a network that does not have a DHCP server, then you will need to configure the IP address manually. The default IP address of the VPort 07-3 Series is 192.168.127.100 and the default subnet mask is 255.255.255.0. Note that you may need to change your computer's IP address and subnet mask so that the computer is on the same subnet as the VPort.

To change the IP address of the VPort manually, access the VPort's web server, and then navigate to the **System Configuration** → **Network** → **General** page to configure the IP address and other network settings. Select the *Use fixed IP address* option to ensure that the IP

address you assign is not deleted each time the VPort is restarted.

**Step 2:** Access the VPort 07-3 Series' web-based manager.

Type the VPort 07-3 IP address in the web browser's address field and press Enter.

**NOTE** If the ActiveX control component for Microsoft Internet Explorer is necessary, enable IE Mode in Microsoft Edge and reload the VPort's web interface while in IE Mode. An IE Mode notification will appear. Make sure both toggles are disabled and the Compatibility Mode is showing IE11, then click **Done**. Refer to the Microsoft website for more information about IE Mode.

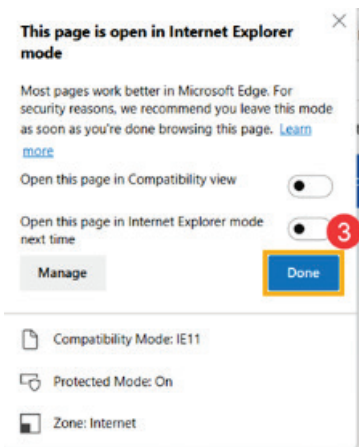

A security warning message will appear when accessing the VPort's web interface in Edge IE Mode for the first time. This message is related to installing the ActiveX Control component onto your PC or notebook. Click Install to install the plug-in to enable viewing video imagery in the IE web browser.

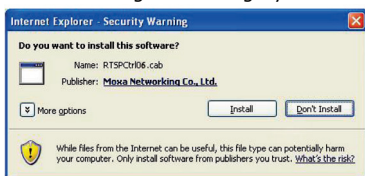

**Step 3:** Log in and change the default password.

When prompted, log in to the VPort's web-based manager. If this is the first time logging in, use the default credentials:

- Username: admin
- Password: moxamoxa

For security reasons, you will need to change the admin password after logging in for the first time. If you log out without changing the password, the Change Password dialog will prompt when you log in the next time. You will need to update the password to proceed with login.

## Change Password

### Admin Password

Admin Password:

Confirm Password:

*Note: Admin password must be either blank, or from 8 to 16 characters.*

**NOTE** For network security reasons, the admin password cannot be reset or changed again. If you forgot the admin password, you will need to send the VPort back to Moxa. Please note that this may incur a service fee.

**Step 4:** Access the homepage of VPort 07-3 Series' web-based manager.

After logging in successfully, the homepage of the VPort 07-3 Series' web-based manager will appear. Check the following items to make sure the system was installed properly:

1. Video Images
2. Video Information

The screenshot displays the VPort P07-3 IP Camera web interface. At the top, there is a green navigation bar with the MOXA logo and the text 'VPort'. Below this, a status bar provides system information: Model Name: VPort, Server Name: VPort P07-3 IP Camera, IP Address: 192.168.1.7/8, MAC Address: 98.90.E8.11.22.08, Firm Version: 1.0, and a user icon labeled '53AT'. The main content area is titled 'VPort P07-3 IP Camera' and features a sidebar with navigation links: System Configuration, Video Information, and Snapshot. The Video Information section is expanded, showing details such as Profile: def\_070101, Encode Type: H.264, Video Size: 1520x1080, and FPS Status: 30. A 'Take' button is located under the Snapshot section. The main area contains a live video feed of a train interior, showing blue seats and handrails. A timestamp '2004/01/01 00:30:10' is visible in the top right corner of the video feed. At the bottom left, there is a 'WEB SERVER' logo and a note: 'Best viewed by IE mode in MS Edge with resolution of 1280x1024'.

**Step 5:** Access the VPort's system configuration.

Click on **System Configuration** to access the overview of the system configuration to change the configuration. **Model Name, Server Name, IP Address, MAC Address, and Firmware Version** appear on the green bar near the top of the page. Use this information to check the system information and installation.

For details of each configuration, check the user's manual available on the Moxa website.

MOXA VPort

System Configuration

Hardware Information

Model: VPort 06/P07-3 Series

Serial Number: 1234567890

MAC Address: 00:00:00:00:00:00

Item	Value	Description
Model	VPort 06/P07-3 Series	Model Name
Serial Number	1234567890	Serial Number
MAC Address	00:00:00:00:00:00	MAC Address
IP Address	192.168.1.1	IP Address
Subnet Mask	255.255.255.0	Subnet Mask
Gateway	192.168.1.1	Gateway
DNS Server	8.8.8.8	DNS Server
Port 1	1000	Port 1
Port 2	1000	Port 2
Port 3	1000	Port 3
Port 4	1000	Port 4
Port 5	1000	Port 5
Port 6	1000	Port 6
Port 7	1000	Port 7
Port 8	1000	Port 8
Port 9	1000	Port 9
Port 10	1000	Port 10
Port 11	1000	Port 11
Port 12	1000	Port 12
Port 13	1000	Port 13
Port 14	1000	Port 14
Port 15	1000	Port 15
Port 16	1000	Port 16
Port 17	1000	Port 17
Port 18	1000	Port 18
Port 19	1000	Port 19
Port 20	1000	Port 20
Port 21	1000	Port 21
Port 22	1000	Port 22
Port 23	1000	Port 23
Port 24	1000	Port 24
Port 25	1000	Port 25
Port 26	1000	Port 26
Port 27	1000	Port 27
Port 28	1000	Port 28
Port 29	1000	Port 29
Port 30	1000	Port 30
Port 31	1000	Port 31
Port 32	1000	Port 32
Port 33	1000	Port 33
Port 34	1000	Port 34
Port 35	1000	Port 35
Port 36	1000	Port 36
Port 37	1000	Port 37
Port 38	1000	Port 38
Port 39	1000	Port 39
Port 40	1000	Port 40
Port 41	1000	Port 41
Port 42	1000	Port 42
Port 43	1000	Port 43
Port 44	1000	Port 44
Port 45	1000	Port 45
Port 46	1000	Port 46
Port 47	1000	Port 47
Port 48	1000	Port 48
Port 49	1000	Port 49
Port 50	1000	Port 50
Port 51	1000	Port 51
Port 52	1000	Port 52
Port 53	1000	Port 53
Port 54	1000	Port 54
Port 55	1000	Port 55
Port 56	1000	Port 56
Port 57	1000	Port 57
Port 58	1000	Port 58
Port 59	1000	Port 59
Port 60	1000	Port 60
Port 61	1000	Port 61
Port 62	1000	Port 62
Port 63	1000	Port 63
Port 64	1000	Port 64
Port 65	1000	Port 65
Port 66	1000	Port 66
Port 67	1000	Port 67
Port 68	1000	Port 68
Port 69	1000	Port 69
Port 70	1000	Port 70
Port 71	1000	Port 71
Port 72	1000	Port 72
Port 73	1000	Port 73
Port 74	1000	Port 74
Port 75	1000	Port 75
Port 76	1000	Port 76
Port 77	1000	Port 77
Port 78	1000	Port 78
Port 79	1000	Port 79
Port 80	1000	Port 80
Port 81	1000	Port 81
Port 82	1000	Port 82
Port 83	1000	Port 83
Port 84	1000	Port 84
Port 85	1000	Port 85
Port 86	1000	Port 86
Port 87	1000	Port 87
Port 88	1000	Port 88
Port 89	1000	Port 89
Port 90	1000	Port 90
Port 91	1000	Port 91
Port 92	1000	Port 92
Port 93	1000	Port 93
Port 94	1000	Port 94
Port 95	1000	Port 95
Port 96	1000	Port 96
Port 97	1000	Port 97
Port 98	1000	Port 98
Port 99	1000	Port 99
Port 100	1000	Port 100

## Wiring Requirements



### ATTENTION

#### Safety First!

Be sure to disconnect the power cord before installing and/or wiring your Moxa VPort 06/P07-3 Series. Calculate the maximum possible current in each power wire and common wire. Observe all electrical codes dictating the maximum current allowable for each wire size. If the current goes above the maximum ratings, the wiring could overheat, causing serious damage to your equipment.

You should also pay attention to the following:

- Use separate paths to route wiring for power and devices. If power wiring and device wiring paths must cross, make sure the wires are perpendicular at the intersection point.
- You can use the type of signal transmitted through a wire to determine which wires should be kept separate. The rule of thumb is that wiring that shares similar electrical characteristics can be bundled together.
- Keep input wiring and output wiring separate.
- We strongly advise labeling wiring to all devices in the system.

## Dimensions (mm)

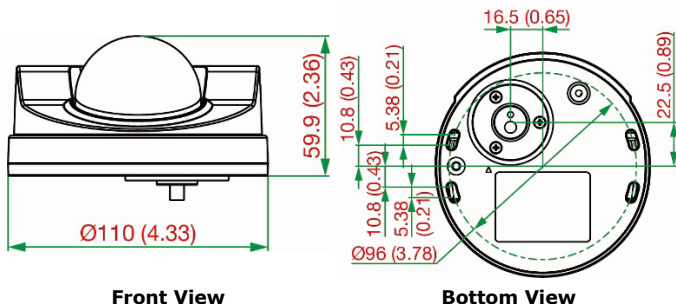

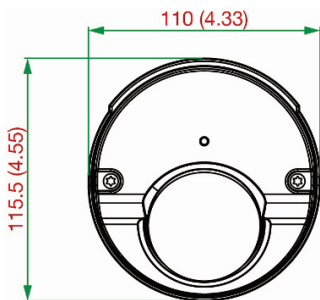

**Top View**

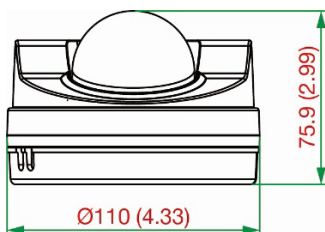

**Camera with SC02 adaptor**

## Specifications

Input Current	VPort 07-3 Series: 0.59 A @ 12 VDC, 0.27 A @ 24 VDC VPort P07-3 Series: 0.137 A @ 48 VDC
Operating Temperature	Standard Models: -40 to 55°C (-40 to 131°F) Wide Temp. Models: -40 to 70°C (-40 to 158°F)



### ATTENTION

The equipment is intended to be supplied by an external power source (UL listed/IEC 60950-1/IEC 62368-1), of which the output complies with ES1/SELV/PS2/LPS, and the output rating is 0.59 A @ 12 VDC, 0.27 @ 24 VDC, 0.137 A @ 48 VDC minimum in ambient temperatures of at least 70°C. If you are using a Class I adapter, the power cord should be connected to an outlet with an earthing connection.