

EDS-G4008シリーズ

8Gポートフルギガビットマネージドイーサネットスイッチ



機能と特長

- IEC 62443-4-1、IEC 62443-4-2産業サイバーセキュリティ標準に準拠
- ネットワーク冗長性のためのTurbo RingとTurbo Chain（リカバリ時間はスイッチ250台で50ms未満）、およびRSTP/STP
- 柔軟な導入のための幅広い電源入力オプション
- 狭いスペースにも収まるコンパクトで柔軟な筐体設計
- 簡単に視覚化された産業用ネットワーク管理を行うためのMXstudioに対応

認証



製品紹介

EDS-G4008シリーズは8つのギガビットイーサネットポートを装備しているため、既存のネットワークをギガビット速度にアップグレードしたり、新しいフルギガビットバックボーンを構築したりするのに最適です。ギガビットの伝送速度は、帯域幅を増やしてパフォーマンスを向上させ、大容量のトリプルプレイサーサービスをネットワーク全体に迅速に転送できます。

Turbo Ring、Turbo Chain、RSTP/STPなどのイーサネット冗長化技術により、システムの信頼性が高まり、ネットワークバックボーンの可用性が向上します。EDS-G4008シリーズは、スケーラブルなバックボーンからメリットを得られる、ビデオおよびプロセス監視、ITS、DCSシステムなどの要求の多いアプリケーション向けに特別に設計されています。

EDS-G4008シリーズは、IEC 62443-4-2およびIEC 62443-4-1産業用サイバーセキュリティ認証に準拠しており、製品のセキュリティとセキュアな開発ライフサイクル両方の要件を網羅していることで、お客様が安全な産業用ネットワーク設計に必要な要件を満たすサポートをします。

仕様

Ethernet Interface

10/100/1000BaseT(X) Ports (RJ45 connector)	8 Auto MDI/MDI-X connection Auto negotiation speed Full/Half duplex mode
Standards	IEEE 802.3 for 10BaseT IEEE 802.3u for 100BaseT(X) IEEE 802.3ab for 1000BaseT(X) IEEE 802.3x for flow control IEEE 802.3ad for Port Trunk with LACP IEEE 802.1Q for VLAN Tagging IEEE 802.1D-2004 for Spanning Tree Protocol IEEE 802.1w for Rapid Spanning Tree Protocol IEEE 802.1p for Class of Service IEEE 802.1X for authentication

Ethernet Software Features

Filter	GMRP, GVRP, GARP, 802.1Q VLAN, IGMP Snooping v1/v2/v3, IGMP Querier
Management	IPv4/IPv6, Flow control, Back Pressure Flow Control, DHCP Server/Client, ARP, RARP, LLDP, Port Mirror, Linkup Delay, SMTP, SNMP Trap, SNMP Inform, SNMPv1/v2c/v3, RMON, TFTP, SFTP, HTTP, HTTPS, Telnet, Syslog, Private MIB
MIB	P-BRIDGE MIB, Q-BRIDGE MIB, IEEE8021-SPANNING-TREE-MIB, IEEE8021-PAE-MIB, IEEE8023-LAG-MIB, LLDP-EXT-DOT1-MIB, LLDP-EXT-DOT3-MIB, SNMPv2-MIB, RMON MIB Groups 1, 2, 3, 9

Redundancy Protocols	STP, RSTP, Turbo Ring v2, Turbo Chain, Ring Coupling, Dual-Homing, Link Aggregation, MSTP
Security	Broadcast storm protection, Rate Limit, Trust access control, Static Port Lock, MAC Sticky, HTTPS/SSL, SSH, RADIUS, TACACS+, Access control list, Login and Password Policy
Time Management	SNTP, NTP Server/Client, NTP Authentication
Protocols	IPv4/IPv6, TCP/IP, UDP, ICMP, ARP, RARP, TFTP, DNS, NTP Client, DHCP Server, DHCP Client, 802.1X, QoS, HTTPS, HTTP, Telnet, SMTP, SNMPv1/v2c/v3, RMON, Syslog

Switch Properties

MAC Table Size	16 K
Jumbo Frame Size	9.216 KB
Max. No. of VLANs	256
VLAN ID Range	VID 1 to 4094
IGMP Groups	512
Priority Queues	4
Packet Buffer Size	1 MB

LED Interface

LED Indicators	PWR1, PWR2, STATE, FAULT, MSTR/HEAD, CPLR/TAIL, SYNC
----------------	--

Serial Interface

Console Port	RS-232 (TxD, RxD, GND), 8-pin RJ45 (115200, n, 8, 1)
--------------	--

USB Interface

USB Connector	USB Type A (Reserved)
---------------	-----------------------

Input/Output Interface

Alarm Contact Channels	1, Relay output with current carrying capacity of 1 A @ 24 VDC
Digital Input Channels	1
Digital Inputs	+13 to +30 V for state 1 -30 to +3 V for state 0 Max. input current: 8 mA
Buttons	Reset button

DIP Switch Configuration

DIP Switches	Turbo Ring, Master, Coupler, Reserve
--------------	--------------------------------------

Power Parameters

Connection	2 removable 4-contact terminal block(s)
Pre-installed Power Module	-LV/-LV-T models: PWR-100-LV -HV/-HV-T models: PWR-105-HV-I
Note	The EDS-G4008 Series supports modular power supplies. The model names and power parameters are determined by the installed power module. For example: EDS-G4008-T + PWR-100-LV = EDS-G4008-LV-T EDS-G4008-T + PWR-105-HV-I = EDS-G4008-HV-T

	If you install a different power module, refer to the specifications of the corresponding model. For example, if you replace the power module of the EDS-G4008-LV-T with the PWR-105-HV-I, refer to the specifications of the EDS-G4008-HV-T.
Input Voltage	-LV/-LV-T models: 12/24/48 VDC, Redundant dual inputs -HV/-HV-T models: 110/220 VDC/VAC, Single input
Operating Voltage	-LV/-LV-T models: 9.6 to 60 VDC -HV/-HV-T models: 88 to 300 VDC, 85 to 264 VAC
Input Current	-LV/-LV-T models: 12-48 VDC, 1.50-0.40 A or 24 VDC, 0.70 A -HV/-HV-T models: 110-220 VAC, 50-60 Hz, 0.30-0.20 A or 110-220 VDC, 0.30-0.20 A
Overload Current Protection	Supported
Reverse Polarity Protection	Supported
Power Consumption (Max.)	EDS-G4008-LV(-T) models: 8.84 W EDS-G4008-HV(-T) models: 10.73 W

Physical Characteristics

IP Rating	IP40
Dimensions	55 x 140 x 120 mm (2.17 x 5.51 x 4.72 in)
Weight	859.5 g (1.89 lb)
Installation	DIN-rail mounting, Wall mounting (with optional kit)
Housing	Metal

Environmental Limits

Operating Temperature	Standard models: -10 to 60°C (14 to 140°F) Wide temp. models: -40 to 75°C (-40 to 167°F)
Storage Temperature (package included)	-40 to 85°C (-40 to 185°F)
Ambient Relative Humidity	5 to 95% (non-condensing)

Standards and Certifications

Industrial Cybersecurity	IEC 62443-4-1 IEC 62443-4-2
Safety	UL 61010-2-201, EN 62368-1 (LVD)
EMC	EN 55032/35, EN 61000-6-2/-6-4
EMI	CISPR 32, FCC Part 15B Class A
EMS	IEC 61000-4-2 ESD: Contact: 8 kV; Air: 15 kV IEC 61000-4-3 RS: 80 MHz to 1 GHz: 20 V/m IEC 61000-4-4 EFT: Power: 4 kV; Signal: 4 kV IEC 61000-4-5 Surge: Power: 4 kV; Signal: 4 kV IEC 61000-4-6 CS: 10 V IEC 61000-4-8 PFMF
Maritime	-LV/-LV-T models: DNV, ABS, NK, LR
Vibration	IEC 60068-2-6
Shock	IEC 60068-2-27
Freefall	IEC 60068-2-32
Railway	EN 50121-4

Traffic Control	NEMA TS2
Power Substation	IEC 61850-3, IEEE 1613 Class 1
Hazardous Locations	Class I Division 2, ATEX, IECEx

MTBF

Time	EDS-G4008-LV/-LV-T models: 1,098,085 hrs EDS-G4008-HV/-HV-T models: 511,204 hrs
Standards	Telcordia SR332

Warranty

Warranty Period	5 years
Details	See www.moxa.com/jp/warranty

Package Contents

Device	1 x EDS-G4008 Series switch
Documentation	1 x quick installation guide 1 x product notice, Simplified Chinese 1 x product certificates of quality inspection, Simplified Chinese 1 x warranty card

寸法

単位：mm (インチ)

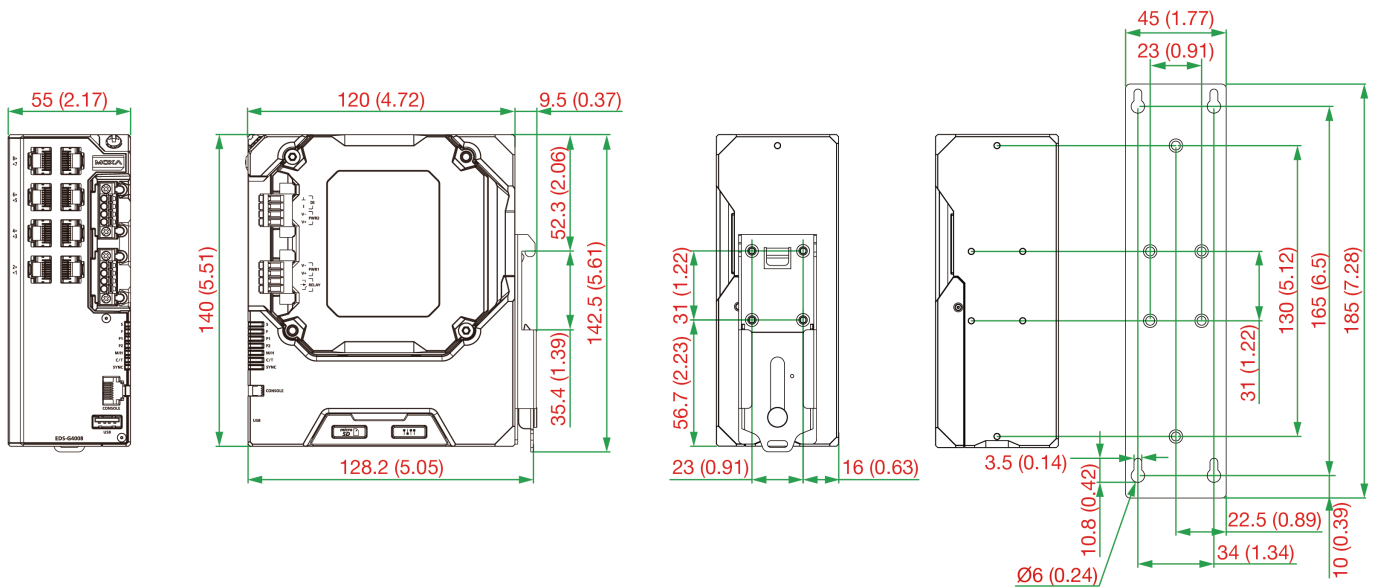

注文情報

Model Name	10/100/1000BaseT(X) Ports, RJ45 Connector	Operating Voltage	Pre-installed Power Module	Operating Temp.
EDS-G4008-LV	8	9.6 to 60 VDC	PWR-100-LV	-10 to 60°C
EDS-G4008-LV-T	8	9.6 to 60 VDC	PWR-100-LV	-40 to 75°C
EDS-G4008-HV	8	88 to 300 VDC, 85 to 264 VAC	PWR-105-HV-I	-10 to 60°C
EDS-G4008-HV-T	8	88 to 300 VDC, 85 to 264 VAC	PWR-105-HV-I	-40 to 75°C

アクセサリ（別売）

Power Supplies

HDR-60-24	60 W/2.5 A DIN-rail 24 VDC power supply, universal 85 to 264 VAC or 120 to 370 VDC input voltage, -30 to 70°C operating temperature
NDR-120-24	120 W/5.0 A DIN-rail 24 VDC power supply, universal 90 to 264 VAC or 127 to 370 VDC input voltage, -20 to 70°C operating temperature
NDR-120-48	120 W/2.5 A DIN-rail 48 VDC power supply, universal 90 to 264 VAC or 127 to 370 VDC input voltage, -20 to 70°C operating temperature
NDR-240-48	240 W/5.0 A DIN-rail 48 VDC power supply, universal 90 to 264 VAC or 127 to 370 VDC input voltage, -20 to 70°C operating temperature
MDR-40-24	DIN-rail 24 VDC power supply with 40W/1.7A, 85 to 264 VAC, or 120 to 370 VDC input, -20 to 70°C operating temperature
MDR-60-24	DIN-rail 24 VDC power supply with 60W/2.5A, 85 to 264 VAC, or 120 to 370 VDC input, -20 to 70°C operating temperature

© Moxa Inc. All rights reserved.2022年10月27日更新。

Moxa Inc.の明白な許可を面で取得しない限り、本書およびその一部の複製や使用はいかなる方法やいかなる場合でも許可されません。製品の仕様は予告なく変更されることがあります。最新の製品情報については当社のWebサイトをご覧ください。