

AWK-1165Aシリーズ

エントリーレベルの5ポート産業用IEEE 802.11ax無線AP



機能と特長

- 高速IEEE 802.11ax Wi-Fi アクセスポイント
- 最大1,201 Mbpsのデータレートを選択可能なデュアルバンドWi-Fi
- 最新のWPA3暗号化によりワイヤレスネットワークのセキュリティが強化
- より柔軟な導入を可能にする、国または地域コードを設定できるユニバーサル (UN)モデル
- より信頼性の高いワイヤレス接続を実現する2.4GHzおよび5GHzバンドパスフィルターを内蔵
- -40~75°Cの幅広い動作温度範囲 (-Tモデル)
- 内蔵アンテナの絶縁設計

認証



製品紹介

AWK-1165Aシリーズの産業用ワイヤレスAPは、IEEE 802.11ax (Wi-Fi 6)テクノロジーを通じてより多くのクライアントにサービスを提供しながら、より高速なデータ転送速度に対する高まるニーズを満たすように設計されています。AWK-1165Aは、動作温度、電源入力電圧、サージ、ESD、振動に関する産業規格および認証に準拠しています。DINレールまたはオプションの壁取り付けを備えたコンパクトなフォームファクタは、産業機械や制御キャビネットに簡単に収まり、信頼性の高いワイヤレスサービスを提供します。AWK-1165Aは、選択可能な2.4 GHzおよび5 GHz帯域をサポートし、既存の802.11a/b/g/n/ac展開との下位互換性があるため、ワイヤレス投資の将来性を確保します。

高度な802.11ac産業用無線ソリューション

- 802.11ax Wi-Fi 6準拠のアクセスポイントは、Wi-Fi 4/Wi-Fi 5との下位互換性があり、柔軟な導入が可能
- DFSチャンネルサポートにより、既存の無線インフラストラクチャからの干渉を回避するために、より広範囲の5 GHzチャンネル選択が可能
- Wi-Fi 6 OFDMA (直交周波数分割多重接続) テクノロジーにより、複数のクライアントとの同時通信が可能になり、ネットワーク効率が向上
- Wi-Fi 6 TWT (ターゲットウェイクタイム) テクノロジーにより、接続されたデバイスのスケジュール設定が改善され、バッテリー寿命が長くなる

高度な ワイヤレス技術

- ローミング機能のないワイヤレスクライアントが最適なアクセスポイントに接続できるようにする、APベースのクライアント接続解除メカニズム

産業用の耐久性

- 外部の電氣的干渉から保護するために内蔵アンテナを絶縁
- 過酷な環境でもスムーズな無線通信を実現する-40~75°Cの広範囲動作温度(-T)モデル

仕様

WLAN Interface

WLAN Standards	2.4 GHz: 802.11ax with 1024 QAM support, 20/40 MHz 5 GHz: 802.11ax with 1024 QAM support, 20/40/80 MHz
Frequency Band for US (20 MHz operating channels)	AWK-1165A-US models only: 2.412 to 2.462 GHz (11 channels) 5.180 to 5.240 GHz (4 channels) 5.260 to 5.320 GHz (4 channels) ¹

1. DFS (動的周波数選択) チャンネルのサポート: In AP mode, when a radar signal is detected, the device will automatically switch to another channel.ただし、規定により、チャンネル切り替え後はサービス開始前に 60 秒間の可用性チェック期間が必要となります。

	5.500 to 5.700 GHz (11 channels) ² 5.745 to 5.825 GHz (5 channels)
Frequency Band for UN (20 MHz operating channels)	AWK-1165A-UN models only: 2.412 to 2.472 GHz (13 channels) 5.180 to 5.240 GHz (4 channels) 5.260 to 5.320 GHz (4 channels) ³ 5.500 to 5.700 GHz (11 channels) ² 5.745 to 5.825 GHz (5 channels) Available channels change depending on the selected country or region code. 5.500 to 5.700 GHz (11 channels) ⁴
Wireless Security	WEP encryption (64-bit and 128-bit) WPA/WPA2/WPA3-Enterprise (IEEE 802.1X/RADIUS, TKIP, AES) WPA/WPA2/WPA3-Personal
Transmission Rate	2.4 GHz: Up to 573.5 Mbps 5 GHz: Up to 1,201 Mbps
Transmitter Power for 802.11a (Dual Chain)	18±1.5 dBm @ 6 Mbps 18±1.5 dBm @ 54 Mbps
Transmitter Power for 802.11n (5 GHz, Dual Chain)	18±1.5 dBm @ MCS0 20 MHz 18±1.5 dBm @ MCS7 20 MHz 18±1.5 dBm @ MCS0 40 MHz 18±1.5 dBm @ MCS7 40 MHz
Transmitter Power for 802.11ac (Dual Chain)	18±1.5 dBm @ MCS0 20 MHz 18±1.5 dBm @ MCS8 20 MHz 18±1.5 dBm @ MCS0 40 MHz 18±1.5 dBm @ MCS9 40 MHz 18±1.5 dBm @ MCS0 80 MHz 18±1.5 dBm @ MCS9 80 MHz
Transmitter Power for 802.11ax (Dual Chain)	18±1.5 dBm @ MCS0 20 MHz 17±1.5 dBm @ MCS11 20 MHz 18±1.5 dBm @ MCS0 40 MHz 17±1.5 dBm @ MCS11 40 MHz 18±1.5 dBm @ MCS0 80 MHz 17±1.5 dBm @ MCS11 80 MHz
Transmitter Power for 802.11b (Dual Chain)	18±1.5 dBm @ 1 Mbps 18±1.5 dBm @ 11 Mbps
Transmitter Power for 802.11g (Dual Chain)	18±1.5 dBm @ 6 Mbps 18±1.5 dBm @ 54 Mbps
Transmitter Power for 802.11n (2.4 GHz, Dual Chain)	18±1.5 dBm @ MCS0 20 MHz 18±1.5 dBm @ MCS7 20 MHz 18±1.5 dBm @ MCS0 40 MHz 18±1.5 dBm @ MCS7 40 MHz
Transmitter Power for 802.11ac (2.4 GHz, Dual Chain)	18±1.5 dBm @ MCS0 20 MHz 18±1.5 dBm @ MCS8 20 MHz 18±1.5 dBm @ MCS0 40 MHz 18±1.5 dBm @ MCS7 40 MHz
Transmitter Power for 802.11ax (2.4 GHz, Dual Chain)	18±1.5 dBm @ MCS0 20 MHz 18±1.5 dBm @ MCS11 20 MHz 18±1.5 dBm @ MCS0 40 MHz 18±1.5 dBm @ MCS11 40 MHz

2. DFS (動的周波数選択) チャンネルのサポート: In AP mode, when a radar signal is detected, the device will automatically switch to another channel. However, according to regulations, after switching channels, a 60-second availability check period is required before starting the service.
3. DFS (動的周波数選択) チャンネルのサポート: In AP mode, when a radar signal is detected, the device will automatically switch to another channel.ただし、規定により、チャンネル切り替え後はサービス開始前に60秒間の可用性チェック期間が必要となります。
4. DFS (Dynamic Frequency Selection) channel support: In AP mode, when a radar signal is detected, the device will automatically switch to another channel.ただし、規定により、チャンネル切り替え後はサービス開始前に60秒間の可用性チェック期間が必要です。

Receiver Sensitivity for 802.11a (measured at 5.680 GHz)	Typ. -88 @ 6 Mbps Typ. -72 @ 54 Mbps
Receiver Sensitivity for 802.11n (5 GHz; measured at 5.680 GHz)	Typ. -88 dBm @ MCS0 20 MHz Typ. -68 dBm @ MCS7 20 MHz Typ. -84 dBm @ MCS0 40 MHz Typ. -66 dBm @ MCS7 40 MHz
Receiver Sensitivity for 802.11ac (5 GHz)	Typ. -88 dBm @ MCS0 20 MHz Typ. -65 dBm @ MCS8 20 MHz Typ. -85 dBm @ MCS0 40 MHz Typ. -60 dBm @ MCS9 40 MHz Typ. -81 dBm @ MCS0 80 MHz Typ. -55 dBm @ MCS9 80 MHz
Receiver Sensitivity for 802.11ax (5 GHz)	Typ. -88 dBm @ MCS0 20 MHz Typ. -59 dBm @ MCS11 20 MHz Typ. -85 dBm @ MCS0 40 MHz Typ. -56 dBm @ MCS11 40 MHz Typ. -81 dBm @ MCS0 80 MHz Typ. -52 dBm @ MCS11 80 MHz
Receiver Sensitivity for 802.11b (measured at 2.437 GHz)	Typ. -96 dBm @ 1 Mbps Typ. -88 dBm @ 11 Mbps
Receiver Sensitivity for 802.11g (measured at 2.437 GHz)	Typ. -90 dBm @ 6 Mbps Typ. -74 dBm @ 54 Mbps
Receiver Sensitivity for 802.11n (2.4 GHz; measured at 2.437 GHz)	Typ. -90 dBm @ MCS0 20 MHz Typ. -70 dBm @ MCS7 20 MHz Typ. -87 dBm @ MCS0 40 MHz Typ. -69 dBm @ MCS7 40 MHz
Receiver Sensitivity for 802.11ac (2.4 GHz)	Typ. -90 dBm @ MCS0 20 MHz Typ. -66 dBm @ MCS6 20 MHz Typ. -87 dBm @ MCS0 40 MHz Typ. -63 dBm @ MCS9 40 MHz
Receiver Sensitivity for 802.11ax (2.4 GHz)	Typ. -90 dBm @ MCS0 20 MHz Typ. -59 dBm @ MCS11 20 MHz Typ. -87 dBm @ MCS0 40 MHz Typ. -56 dBm @ MCS11 40 MHz
WLAN Operation Mode	Access point Master Sniffer
Antenna	External, 2/2 dBi Omni-directional
Antenna Connectors	2 RP-SMA female

Ethernet Interface

Standards	IEEE 802.3 for 10BaseT IEEE 802.3u for 100BaseT(X) IEEE 802.3ab for 1000BaseT(X) IEEE 802.3az for Energy-Efficient Ethernet IEEE 802.1Q for VLAN Tagging IEEE 802.1X for authentication
10/100/1000BaseT(X) Ports (RJ45 connector)	5

Ethernet Software Features

Management	DHCP Server DHCP Client DNS HTTP IPv4 LLDP SMTP SNMPv1/v2c/v3 Syslog TCP/IP Telnet UDP VLAN MXconfig
Security	HTTPS/SSL RADIUS SSH Certificate Management
Time Management	SNTP Client

Firewall

Filter	ICMP MAC address IP protocol Port-based Wi-Fi ACL Client Isolation
--------	---

Serial Interface

Console Port	RS-232 8-pin RJ45
--------------	----------------------

USB Interface

Storage Port	USB Type A
--------------	------------

LED Interface

LED Indicators	PWR, WLAN, SYSTEM
----------------	-------------------

Input/Output Interface

Buttons	Reset button
---------	--------------

Physical Characteristics

Housing	Metal
IP Rating	IP30
Dimensions	AWK-1165A models: 60 x 100 x 53 mm (2.36 x 3.94 x 2.09 in) AWK-1165A-T models: 60 x 100 x 66 mm (2.36 x 3.94 x 2.60 in)
Weight	AWK-1165A models: 428.5 g (0.94 lb) AWK-1165A-T models: 516.5 g (1.14 lb)
Installation	DIN-rail mounting Wall mounting (with optional kit)

Power Parameters

Input Current	9 to 30 VDC, 1.57 to 0.47 A
Input Voltage	9 to 30 VDC

Power Connector	1 removable 3-contact terminal block(s)
Power Consumption	14 W (max.)

Environmental Limits

Operating Temperature	Standard Models: -25 to 60°C (-13 to 140°F) Wide Temp. Models: -40 to 75°C (-40 to 167°F)
Storage Temperature (package included)	-40 to 85°C (-40 to 185°F)
Ambient Relative Humidity	5 to 95% (non-condensing)

Standards and Certifications

EMC	EN 61000-6-2/-6-4 EN 55032/35
EMI	CISPR 32, FCC Part 15B Class A
EMS	IEC 61000-4-2 ESD: Contact: 8 kV; Air: 15 kV IEC 61000-4-3 RS: 80 MHz to 1 GHz: 10 V/m IEC 61000-4-4 EFT: Power: 2 kV; Signal: 1 kV IEC 61000-4-5 Surge: Power: 2 kV; Signal: 1 kV IEC 61000-4-6 CS: 10 V/m IEC 61000-4-8 PFMF: 30 A/m
Road Vehicles	E mark E1
Safety	IEC 62368-1 UL 62368-1
Vibration	IEC 60068-2-6
Radio	EN 300 328, EN 301 489-1/17, EN 301 893, ANATEL, FCC, MIC, NCC, RCM, SRRC, WPC, KC, NBTC, IC

MTBF

Time	4,002,106 hrs
Standards	Telcordia SR332

Warranty

Warranty Period	5 years
Details	See www.moxa.com/jp/warranty

Package Contents

Device	1 x AWK-1165A Series wireless AP
Installation Kit	1 x DIN-rail kit
Antenna	2 x 2.4/5 GHz antenna
Documentation	1 x quick installation guide 1 x warranty card

寸法

標準モデル

単位: mm (インチ)

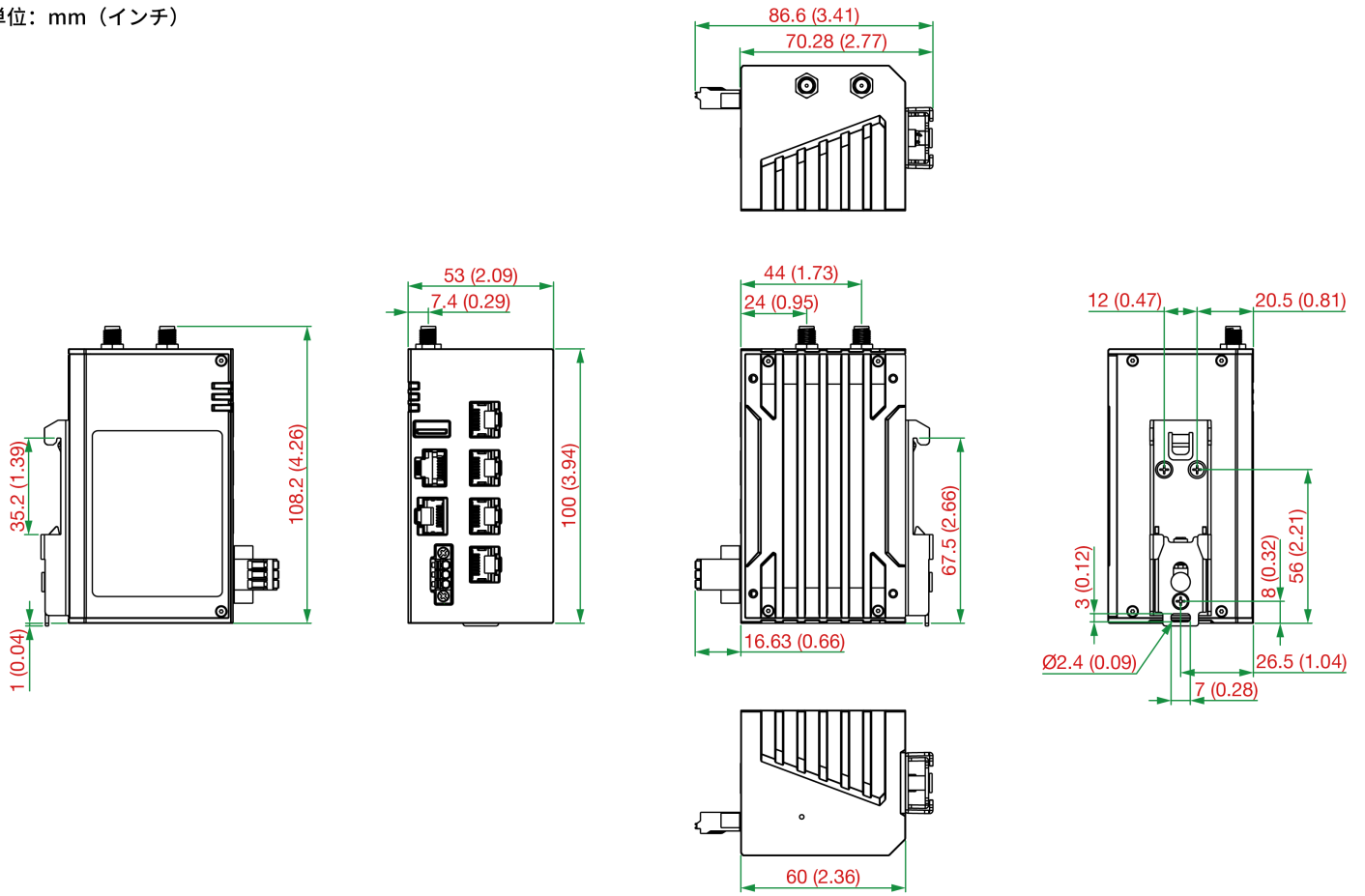

広範囲温度(-T)モデル

単位: mm (インチ)

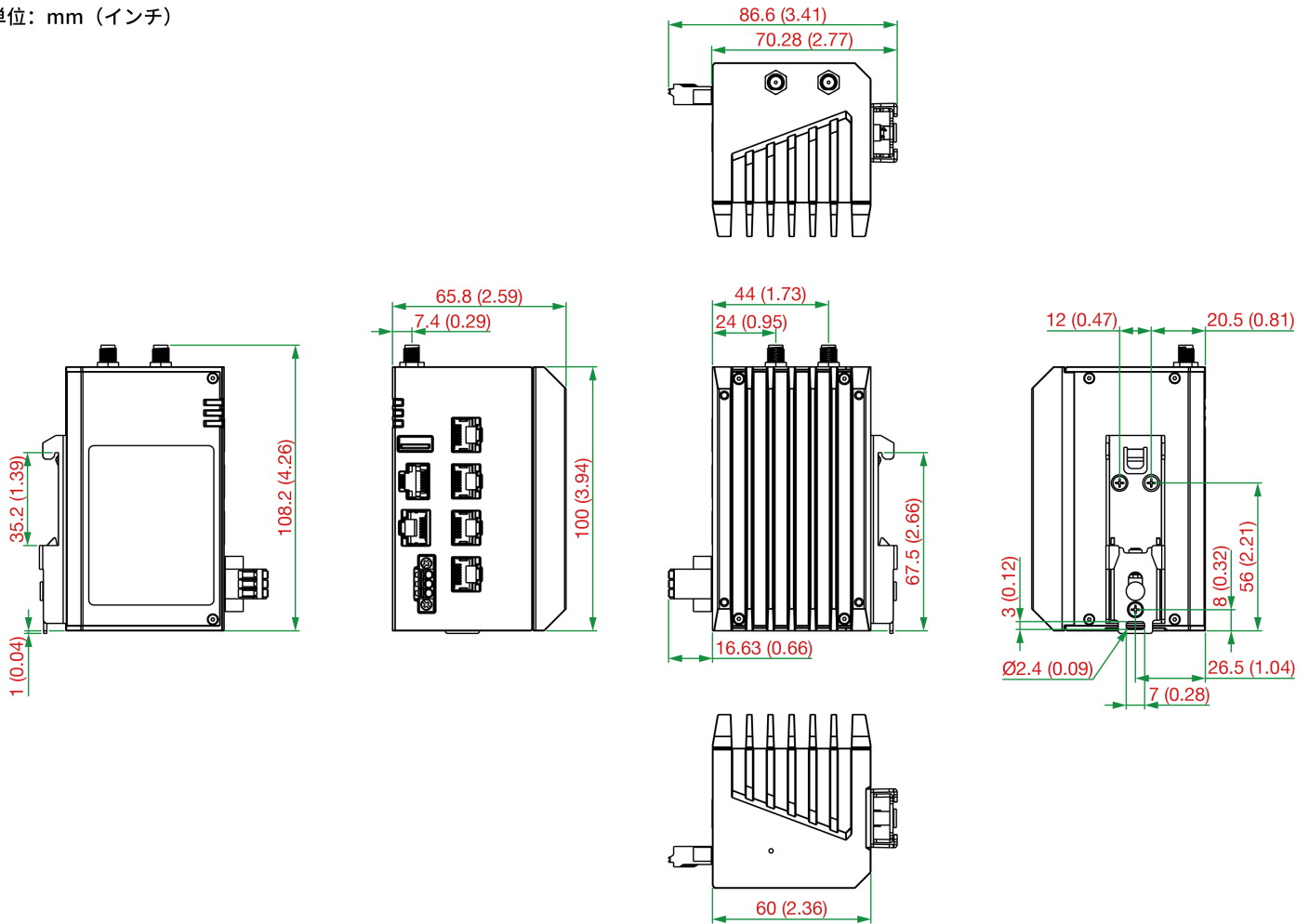

注文情報

Model Name	Band	Standards	Operating Temp.
AWK-1165A-UN	UN	802.11ax (Wi-Fi 6)	-25 to 60°C
AWK-1165A-UN-T	UN	802.11ax (Wi-Fi 6)	-40 to 75°C
AWK-1165A-US	US	802.11ax (Wi-Fi 6)	-25 to 60°C
AWK-1165A-US-T	US	802.11ax (Wi-Fi 6)	-40 to 75°C

アクセサリ (別売)

Antennas

ANT-WSB-PNF-12-02	12 dBi at 2.4 GHz, N-type (female), single-band directional antenna
ANT-WSB5-PNF-16	16 dBi at 5 GHz, N-type (female), single-band directional antenna
ANT-WDB-ONM-0707	07 dBi at 2.4 GHz and 07 dBi at 5 GHz, N-type (male), dual-band omnidirectional antenna
ANT-WDB-PNF-1011	10 dBi at 2.4 GHz and 11 dBi at 5 GHz, N-type (female), dual-band directional antenna
ANT-WDB-ONF-0709	7 dBi at 2.4 GHz or 9 dBi at 5 GHz, N-type (female), dual-band, omnidirectional antenna
ANT-WDB-ANM-0306	3 dBi at 2.4 GHz or 6 dBi at 5 GHz, N-type (male), omnidirectional antenna
ANT-WDB-ARM-02	2 dBi at 2.4 GHz or 2 dBi at 5 GHz, RP-SMA (male) omnidirectional rubber-duck antenna
ANT-WDB-ARM-0202	2 dBi at 2.4 GHz or 2 dBi at 5 GHz, RP-SMA (male), dual-band, omnidirectional antenna
ANT-WSB-AHRM-05-1.5m	5 dBi at 2.4 GHz, RP-SMA (male), omnidirectional/dipole antenna, 1.5 m cable
MAT-WDB-CA-RM-2-0205	2.4/5 GHz, ceiling antenna, 2/5 dBi, MIMO 2x2, RP-SMA-type (male)

MAT-WDB-DA-RM-2-0203-1m	2.4/5 GHz, desktop antenna, 2/3 dBi, MIMO 2x2, RP-SMA-type (male), 1 m cable
MAT-WDB-PA-NF-2-0708	2.4/5 GHz, panel antenna, 7/8 dBi, MIMO 2x2, N-type (female)
ANT-WDB-ANM-0502	5 dBi at 2.4 GHz or 2 dBi at 5 GHz, N-type (male), omnidirectional antenna

Wireless Antenna Cables

A-CRF-RFRM-R4-150	Wireless antenna cable with RP-SMA (female) to RP-SMA (male) connectors, magnetic base, RG-174 type, 1.5 m
A-CRF-RMNM-L1-300	N-type (male) to RP SMA (male) LMR-195 Lite cable, 3 m
A-CRF-RMNM-L1-600	N-type (male) to RP SMA (male) LMR-195 Lite cable, 6 m
A-CRF-RMNM-L1-900	N-type (male) to RP SMA (male) LMR-195 Lite cable, 9 m

Surge Arrestors

A-SA-NMNF-02	0 to 6 GHz, N-type (male) to N-type (female) surge arrester
A-SA-NFNF-02	0 to 6 GHz, N-type (female) to N-type (female) surge arrester

Wireless Terminating Resistors

A-TRM-50-NM	50-ohm termination resistor with N-type male connector
-------------	--

Wall-Mounting Kits

WK-56-01	Wall-mounting kit with 2 plates (56 x 33.3 x 2 mm) and 4 screws
----------	---

© Moxa Inc. All rights reserved. 2024年6月21日更新。

Moxa Inc.の明白な許可を画面で取得しない限り、本書およびその一部の複製や使用はいかなる方法やいかなる場合でも許可されません。製品の仕様は予告なく変更されることがあります。最新の製品情報については当社のWebサイトをご覧ください。