

MRC-1002 Series Quick Installation Guide

Moxa Remote Connect Gateway

Edition 3.0, September 2020

Technical Support Contact Information **www.moxa.com/support**

Moxa Americas:

Toll-free: 1-888-669-2872

Tel: 1-714-528-6777

Fax: 1-714-528-6778

Moxa China (Shanghai office):

Toll-free: 800-820-5036

Tel: +86-21-5258-9955

Fax: +86-21-5258-5505

Moxa Europe:

Tel: +49-89-3 70 03 99-0

Fax: +49-89-3 70 03 99-99

Moxa Asia-Pacific:

Tel: +886-2-8919-1230

Fax: +886-2-8919-1231

Moxa India:

Tel: +91-80-4172-9088

Fax: +91-80-4132-1045



© 2020 Moxa Inc. All rights reserved.

P/N: 1802010020013



Overview

The MRC-1002 Series is the gateway part of the Moxa Remote Connect Solution, which connects remote Ethernet-based industrial equipment to the Moxa Remote Connect Server. This allows service engineers to access the equipment on the local network remotely.

Package Checklist

Before installing the MRC-1002 Series, please verify that the package contains the following items:

- MRC-1002 series gateway x 1
- Wireless Antenna x 2 (LTE model only)
- Quick installation guide (printed)
- Moxa product warranty statement

MRC-1002 and MRC-1002-LTE Panel Layout

The following figures show the panel layouts of the MRC-1002 Series.

Top and Bottom View

Top View

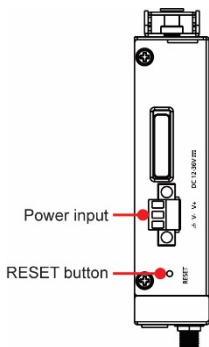

Bottom View

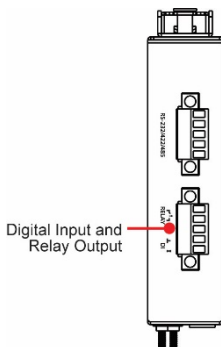

Front View



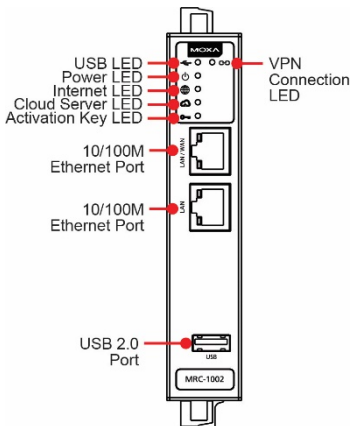



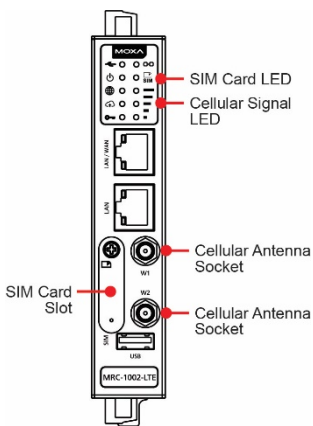

MRC-1002



MRC-1002-LTE



LED Indicators

LED Symbol	LED Name	Color	Function
	USB	Green	Steady On: The USB device is connected and working Steady Off: The USB device is not connected
	Power	Green	Steady On: The gateway is powered on Steady Off: The gateway is powered off
	Internet	Green	Blinking: Testing the Internet connectivity Steady On: Internet is available
	Cloud Server	Green	Steady Off: WAN configuration is not available Blinking: Testing the connectivity of the MRC Server Steady On: The MRC Server is connected
	Activation Key	Green	Steady Off: There is no activation key inside the gateway Blinking: The activation key is not valid Steady On: The activation key is valid and the gateway is activated
	Connection	Green	Blinking: The gateway is trying to establish the VPN tunnel Steady On: The gateway has successfully established the VPN tunnel
	SIM	Green	Steady Off: No SIM card Blinking: SIM card error Steady On: SIM card is ready
	Cellular Signal	Green	There are three LEDs to display the signal strength of the cellular. 3 LEDs On: Highest strength signal 2 LEDs On: Normal strength signal 1 LED On: Signal quality is poor (possibly no Internet connection) 0 LED On: No Internet connection
	Ethernet Speed		Ethernet port is connected with a speed of 10 Mbps / 100M speed

Mounting Dimensions (unit: mm [inch])

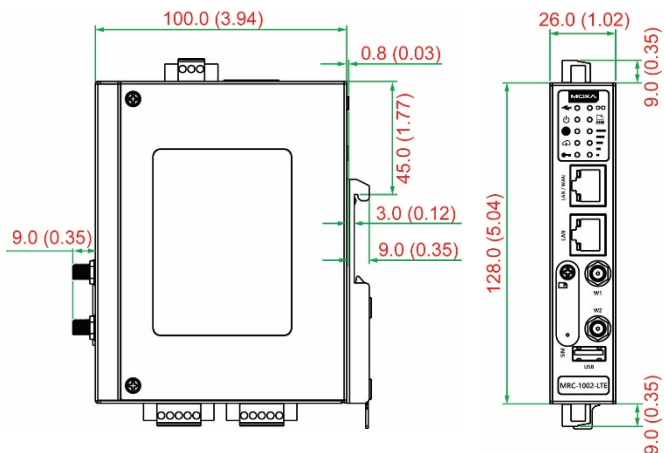

DIN-rail mounting

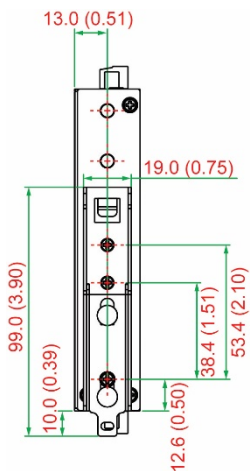

Wall-mounting

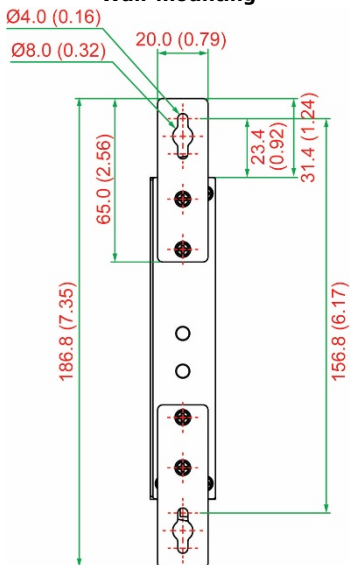

Installing the MRC-1002 Gateway

The metal DIN-rail kit is fixed to the back panel of the MRC-1002 gateway when you take it out of the box. Mount the MRC-1002 gateway on corrosion-free mounting rails that meet the EN 60715 standard.

STEP 1:

Click on the DIN rail and push down into the mounting rail.

STEP 2:

Push the MRC-1002 gateway forward until it snaps into place.

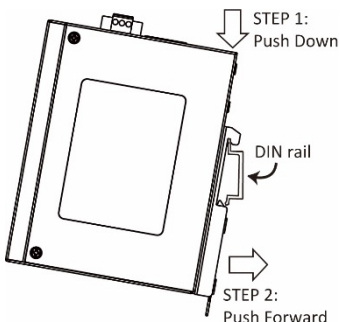

Removing the MRC-1002 Gateway

STEP 1:

Use a flat-type screwdriver to pull down the spring of the DIN rail kit.

STEP 2:

Pull back the MRC-1002 gateway until it releases from the mounting rail.

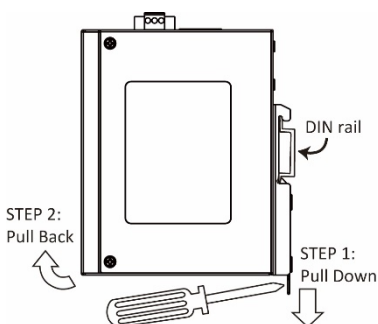

Wiring Requirement



WARNING

Do not disconnect modules or wires unless the power has been switched off or the area is known to be non-hazardous. The devices may only be connected to the supply voltage shown on the type plate. The devices are designed for operation with a Safety Extra-Low Voltage. Thus, they may only be connected to the supply voltage connections and to the signal contact with the Safety Extra-Low Voltages (SELV) in compliance with IEC950/ EN 60950/VD E0805/IEC 61010 class 2.



ATTENTION

This unit is a built-in open type. When the unit is installed in another piece of equipment, the equipment enclosing the unit must comply with fire enclosure regulation IEC 60950/EN60950 (or similar regulation).



ATTENTION

Safety First!

Be sure to disconnect the power cord before installing and/or wiring your MRC-1002 gateway.

Calculate the maximum possible current in each power wire and common wire. Observe all electrical codes dictating the maximum current allowable for each wire size. If the current goes above the maximum rating, the wiring could overheat, causing serious damage to your equipment.

Please read and follow these guidelines:

- Use separate paths to route wiring for power and devices. If power wiring and device wiring paths must cross, make sure the wires are perpendicular at the intersection point. NOTE: Do not run signal or communications wiring and power wiring through the same wire conduit. To avoid interference, wires with different signal characteristics should be routed separately.
- You can use the type of signal transmitted through a wire to determine which wires should be kept separate. The rule of thumb is that wiring that shares similar electrical characteristics can be bundled together.
- You should separate input wiring from output wiring.
- We advise that you label the wiring to all devices in the system.

Wiring the Power Input (12-36V DC)

Connect the power adapter with the 3-pin terminal block on the top panel of the MRC-1002 gateway and push the power terminal block into the terminal block socket. When the system boots up, the system is ready, and the Power LED will light up.

STEP 1: Insert the negative/positive DC wires into the V-/V+ terminals, respectively.

STEP 2: To keep the DC wires from pulling loose, use a small flat-blade screwdriver to tighten the wire-clamp screws on the front of the terminal block connector.

STEP 3: Insert the plastic terminal block connector prongs into the terminal block receptor located on the top panel of the MRC-1002 gateway.

STEP 1 / STEP 2:

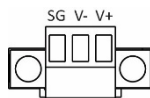

STEP 3:

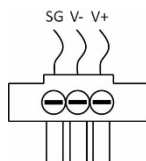

ATTENTION

Before connecting the MRC-1002 gateway to the DC power input, make sure the DC power source voltage is stable. The wire must be able to withstand at least 105°C.

Grounding the MRC-1002 Gateway

Grounding and wire routing help limit the effects of noise due to electromagnetic interference (EMI). Run the ground connection from the terminal block to the grounding surface prior to connecting devices.



ATTENTION

This product is intended to be mounted to a well-grounded mounting surface such as a metal panel.

Wiring the Relay Contact

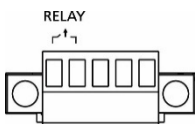

The MRC-1002 Series has one relay output. This relay contact uses two contacts of the terminal block on the bottom panel of the MRC-1002 gateway. Refer to the next section for detailed instructions on how to connect the wires to the terminal block connector, and how to attach the terminal block connector to the terminal block receptor. In this section, we illustrate the meaning of the two contacts used to connect the relay contact.

FAULT:

The two contacts of the 5-pin terminal block connector are used to detect user-configured events. The two wires attached to the fault contacts form an open circuit when a user-configured event is triggered. If a user-configured event does not occur, the fault circuit remains closed.

Wiring the Digital Input

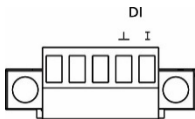

The MRC-1002 gateway has one digital input (DI). The DI consists of two contacts of the 5-pin terminal block connector on the MRC-1002 bottom panel, which are used for the DC input. The top view of the terminal block connectors is shown above.

STEP 1: Insert the negative (ground)/positive DI wires into the \pm /I terminals, respectively.

STEP 2: To keep the DI wires from pulling loose, use a small flat-blade screwdriver to tighten the wire-clamp screws on the front of the terminal block connector.

STEP 3: Insert the plastic terminal block connector prongs into the terminal block receptor, which is located on the bottom panel of the MRC-1002 gateway.

Wiring the Serial Ports

The MRC-1002 gateway has one serial port. Each port can be configured by software for RS-232, RS-422, or RS-485. The pin assignments for the ports are shown in the following table.

Pin	RS-232	RS-422	RS-485
1	TXD	TXD+	-
2	RXD	TXD-	-
3	RTS	RXD+	D+
4	CTS	RXD-	D-
5	GND	GND	GND

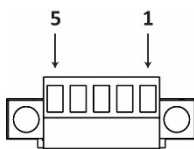

SIM Card Socket

The MRC-1002 gateway LTE version comes with a SIM card socket (normal SIM size) for cellular communications. The SIM card socket is located at the lower part of the front panel. To install them, remove the screw and the protection cover to access the socket, and then plug the SIM card into the socket directly. You will hear "click" when finished. Push the SIM card again to release it from the socket.

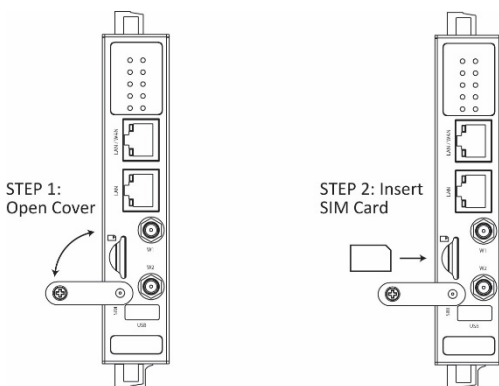

Cellular Antenna

The MRC-1002 gateway cellular version has two antennas in the package. Screw the antennas into the cellular sockets marked as W1 and W2 on the front panel.

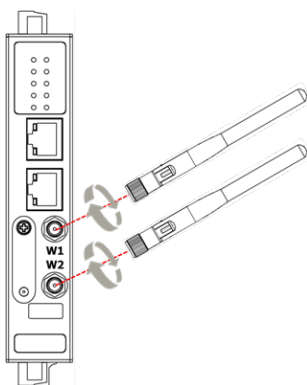

USB Port

The USB 2.0 port (type A connector) is located at the lower part of the front panel, and supports a USB storage device driver for FAT, FAT32 and NTFS. The pinout of the USB port is as below.

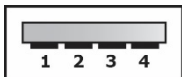

Pin	Description
1	VCC (+5V)
2	D- (Data-)
3	D+(Data+)
4	GND (Ground)

Ethernet Ports

The 10/100BaseT(X) ports located on the front panel of the MRC-1002 gateway are used to connect to Ethernet-enabled devices. The ports are at "Auto MDI/MDI-X" mode by default, which is suitable for straight-through or cross-over Ethernet cables. In what follows, we give pinouts for both MDI (NIC-type) ports and MDI-X (HUB/Switch-type) ports. We also give cable wiring diagrams for straight-through and cross-over Ethernet cables.

MDI Port Pinouts

Pin	Signal
1	Tx+
2	Tx-
3	Rx+
6	Rx-

MDI-X Port Pinouts

Pin	Signal
1	Rx+
2	Rx-
3	Tx+
6	Tx-

8-pin RJ45

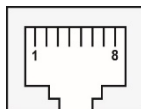

Connecting to a PC

Web Console

The MRC-1002 gateway provides local HTTP web console for users to configure the settings from the LAN port. The web console is also available for the remote Moxa Remote Connect Clients within the same device group in the same Moxa Remote Connect Server. The default network configuration, login account, and password are shown below.

- Management LAN IP:
192.168.127.254
- Administration login /
password: admin / moxa

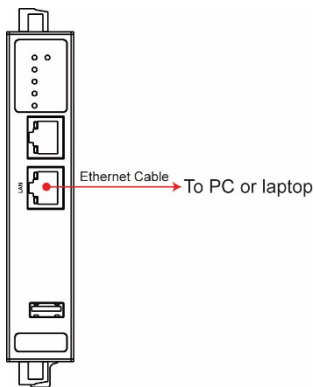

Reset Button

The MRC-1002 gateway has a reset button on the top of the panel. Push down the button with a pin and the gateway will reset to default. Pressing and releasing the button for different durations has different actions as listed below.

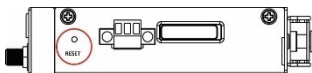

Operation	LED (Blinking)	Action
Press and release within 1 to 5 seconds	Internet LED	Reboot MRC Gateway
Press and release within 6 to 10 seconds	Internet LED + Cloud Server LED	Reset login account and password to default (admin / moxa) Reset to default LAN interface 192.168.127.254
Press and release within 11 to 15 seconds	Internet LED + Cloud Server LED + Activation Key LED	Reset all configurations, activation key, and certificate
Press longer than 15 seconds and release	N/A	Cancel the reset operation

Specifications

Power	
Input Voltage	12-36 VDC
Input Current	0.62 A (max.) @ 12 VDC
Connection	1 removable 3-contact terminal block
Overload Current Protection	Supported
Reverse Polarity Protection	Supported
Physical Characteristics	
Housing	Metal, IP30 protection
Dimensions	101 x 27 x 128 mm (3.98 x 1.06 x 5.04 in)
Installation	DIN-rail mounting, wall mounting (optional kit)
Interface	
RJ-45 Port	10/100BaseT(X): 2 ports
USB Port	1
Button	RESET button
LED Indicator	USB, Power, Internet, Cloud Server, Activation Key, Connection, SIM Card, Cellular Signals
Alarm Contact	1 relay output with current carrying capacity of 1 A @ 24 VDC
Digital Input	1 input with the same ground, but electrically isolated from the electronics. <ul style="list-style-type: none"> +13 to +30 V for state "1"

	<ul style="list-style-type: none"> -30 to +3 V for state "0" Max. input current: 8 mA
Environmental Limits	
Operating Temperature	Standard models: -10 to 60°C (-14 to 140°F) Wide temperature models: MRC-1002-T: -40 to 75°C (-40 to 167°F) MRC-1002-LTE-XX-T Series: -30 to 70°C (-22 to 158°F)
Storage Temperature	-40 to 85°C (-40 to 185°F)
Ambient Relative Humidity	5 to 95% (non-condensing)
Altitude	Up to 2000 m (Please contact Moxa if you require products guaranteed to function properly at higher altitudes.)
IEC/UL 61010	Indoor use and pollution degree 2. The requirement must be wiped with a dry cloth.
Regulation Approvals	
Safety	UL 61010-2-201
EMI	FCC Part 15B Class A
EMC	MRC-1002-T: EN 55032/24 MRC-1002-LTE-EU Series: EN 55032/35
EMS	IEC 61000-4-2 IEC 61000-4-3 IEC 61000-4-4 IEC 61000-4-5 IEC 61000-4-6 IEC 61000-4-8
Shock	IEC 60068-2-27
Free Fall	IEC 60068-2-32
Vibration	IEC 60068-2-6
Carrier Approval	AT&T (recommended to use the ANT-5G-ASM-07 antenna) Verizon (recommended to use the ANT-5G-ASM-07 antenna)
Warranty	
Warranty Period	5 years